



# **Spectral Absorption and Attenuation Sensor**

ac-s

User's Guide

WET Labs, Inc.  
P.O. Box 518  
Philomath, OR 97370  
541 929-5650  
[www.wetlabs.com](http://www.wetlabs.com)



## Warranty

This sensor is guaranteed against defects in materials and workmanship for one year from the original date of purchase. Warranty is void if the factory determines the sensor was subjected to abuse or neglect beyond the normal wear and tear of field deployment, or in the event the pressure housing has been opened by the customer.

To return the sensor, contact WET Labs for a Return Merchandise Authorization (RMA) and ship in the original container. WET Labs is not responsible for damage to sensors during the return shipment to the factory. WET Labs will supply all replacement parts and labor and pay for return via 3<sup>rd</sup> day air shipping in honoring this warranty.

---

## Return Policy for Instruments with Anti-fouling Treatment

WET Labs cannot accept sensors for servicing or repair that are treated with anti-fouling compound(s). This includes but is not limited to tri-butyl tin (TBT), marine anti-fouling paint, ablative coatings, etc.

Please ensure any anti-fouling treatment has been removed prior to returning sensors to WET Labs for service or repair.

---

## Shipping Requirements

1. Please retain the original ruggedized shipping case. It meets stringent shipping and insurance requirements, and protects the sensor.
  2. Service and repair work cannot be guaranteed unless the sensor is shipped in its original case.
  3. Clearly mark the RMA number on the outside of your case and on all packing lists.
  4. Return instruments using 3<sup>rd</sup> day air shipping or better: do **not** ship via ground.
- 



Electrical equipment marked with this symbol may not be disposed of in European public disposal systems. In conformity with EU Directive 2002/96/EC (as amended by 2003/108/EC), European users of electrical equipment must return old or end-of-life equipment to the manufacturer for disposal at no charge to the user.

---





## Table of Contents

<b>1. Setup and Testing</b> .....	<b>1</b>
1.1 Remove and Replace Flow Tubes and Sleeves.....	1
1.2 Install WETView .....	1
1.3 Bench Testing .....	2
1.4 Air Tracking.....	2
1.5 Cleaning .....	4
1.6 System Requirements.....	6
<b>2. Operation</b> .....	<b>7</b>
2.1 Basic Power On.....	7
2.2 Mounting and Deployment .....	7
2.3 Data Collection .....	10
2.4 Care and Maintenance.....	10
<b>3. Data Processing</b> .....	<b>11</b>
3.1 Analog Acquisition.....	11
3.2 Analog-to-Digital Conversion .....	11
3.3 Digital Processing and Data Output.....	11
3.4 Data Format .....	12
3.5 Post Processing .....	12
3.6 Temperature and Salinity Correction.....	14
3.7 Reflective Tube Scattering Correction.....	15
<b>4. Manufacturer's Calibration</b> .....	<b>17</b>
4.1 Temperature Correction .....	17
4.2 Precision.....	18
4.3 Absolute Calibration .....	18
4.4 Linearity and Dynamic Range .....	18
4.5 Air Calibration and Tracking .....	18
<b>5. Specifications</b> .....	<b>19</b>
5.1 Connectors .....	19
<b>6. Technical Reference</b> .....	<b>21</b>
6.1 Mechanical.....	21
6.2 Optics .....	21
6.3 Electronics.....	21
6.4 Signal Processing.....	21
<b>Appendix A: Data Record Format</b> .....	<b>21</b>
Primary Processing .....	23
<b>Appendix B: Common Mode A/C Induced Noise</b> .....	<b>25</b>





## 1. Setup and Testing

The ac-s is delivered with the following components:

- dummy plug with lock collar
- this manual
- WETView User's Guide
- additional reference: ac-9 Protocol Document
- WETView software and sensor-specific calibration information
- Ten-foot test cable
- double "Y" de-bubbler tubing
- stainless steel intake screens

### 1.1 Remove and Replace Flow Tubes and Sleeves

1. Grasp the metal nozzles with the black plastic caps that are on each flow tube and slide them toward the middle of the flow tube. These are the flow sleeves. They only need to slide about ½ in. to unlock the flow tube from its fixed position.
2. Lift the flow tube from the body of the sensor.
3. Do these steps for the other flow tube.
4. Examine the differences in the flow tubes and sleeves.
  - The attenuation, or "c" tube is plastic and the two sleeves on the tube are identical. This tube installs on the "c" side of the sensor (the side with the identical-looking windows).
  - The absorption, or "a" tube is lined with a quartz tube. One of the two sleeves is flat on top and has no lip. This tube installs on the "a" side of the sensor, which can be identified by the "a" detector window on the upper flange. This window looks different from the other three. The flat flow sleeve goes on this detector.

### 1.2 Install WETView

1. Insert the WETView CD in the host computer.
2. Double-click on the SETUP.EXE icon. Setup will guide you through the rest of the installation process.
  - When installed, the following files should be on the hard disk:  
WETVIEW.EXE, WETVIEW.UIR.
3. Copy the calibration files for the sensor from the manufacturer-supplied CD. The name of the file takes the form AIRXXYYY.CAL where XX is the calibration number and YYY is the sensor serial number.

#### Caution

Rename any existing device files or archive them in a different directory so that they will not be overwritten.

---



### 1.3 Bench Testing

The following items are needed to bench test the ac-s:

- A clean, solid lab table or work bench
  - The ac-s with 10-foot test cable (or sea cable)
  - A 10–35 volt power supply (the ac-s requires 10–35 VDC)
  - A PC with WETView installed.
1. Connect the test cable to COMM1–COMM4 of the host PC. Connect the power leads to the power supply. The black lead is the V+ lead. Before connecting the cable to the instrument, use a multimeter to check the input power.
  2. Turn the power supply off.
  3. Connect the test cable to the sensor. Apply power to the sensor and allow it to begin warming up.
  4. Run WETView. Select the device file.
  5. Click on the <O> button in the center top of the screen or choose **Open Device File** from the **File** menu at the top left of the screen. The program will ask you to choose the proper COMM port. Select COMM1 through COMM4 as appropriate. Note that WETView supports COMM1 through COMM4 only.
  6. Click on the center button or <F1> to start displaying data. After 5–10 seconds, tabular data should be displayed on the right side of the screen. A real time graph will begin to develop, depending on the graph parameters set at the time. Refer to the WETView User's Guide for details of running the WETView software.
  7. After a short time, again click on the center button that will stop the data collection and ask for a file name to apply to the data. Press ESC if you do not want to save the data. To quit the program, choose **QUIT** from the **File** menu.

### 1.4 Air Tracking

WET Labs provides an air calibration (.CAL) file similar to the device (.DEV) file.

- The DEV file provides the clean water offsets so that when measuring clean, fresh water, the sensor's output should be very close to 0.0 for all channels.
- The .CAL file provides the offsets that provide 0.0 values when the sensor is clean and dry and measuring air values. This is a useful tool for tracking sensor drift, filter aging and improper cleaning.

If the air values taken in the field differ from factory air values, then that difference may be applied as a correction factor to the original water calibration values contained in the DEV file:

$$a'_{\text{clean}} = a_{\text{clean}} + (a'_{\text{air}} - a_{\text{air}}) \quad (1)$$

Where:

$a_{\text{clean}}$  is the clean water offset value supplied with the ac sensor





- $a'_{\text{clean}}$  is the corrected clean water offset
- $a_{\text{air}}$  is the factory supplied air value
- $a'_{\text{air}}$  is the field obtained air values

Alternatively, the offset air value difference can be applied directly to the data as a post-processing step. Obtaining air values in the field is a much more straightforward process than obtaining clean water values. This is a powerful technique that can track and compensate for sensor drift and filter aging. Care must be taken when implementing this technique since a drop of water or smudge on the windows will result in a reading quite different from the factory air values. This difference might be interpreted as sensor drift. By iterating this process several times (re-cleaning the sensor and obtaining a new set of air values), you will gain experience in differentiating true sensor drift from smudged optics.

#### **Caution**

**Back up the factory DEV file before making any modifications to it.**

---

Effective air calibration requires:

1. The sensor's optical path is clean and dry.
2. The sensor's optical path is completely shielded from ambient light.
3. The instrument maintains an internal temperature value within its calibration range.

To perform air tracking:

1. Remove flow tubes and clean and dry completely. Remove the sleeves from the flow tubes to assure there is no trapped moisture. Allow the flow tubes to sit in a dry environment with good air flow.
2. Clean and completely dry the optical windows of the sensor. If the optics have not been cleaned for some time, clean with a mild solution of detergent and distilled water, rinse, and wipe dry. Follow with a single wipe across each window with an ethanol-soaked lens tissue (or other low water content alcohol-type solvent) and then a single-wipe with a dry tissue. If the windows are already fairly clean, simply use the ethanol wipe procedure. You may wish to apply a stream of pressurized air or nitrogen around the windows to force moisture from the window mount.

#### **Caution**

**Beware of using standard air compressor air. It can blow oil all over the optics.**

---

3. Allow the sensor to sit open for an hour or two to assure that it dries.
4. Reassemble and insert flow tubes.
5. Turn on sensor and allow it to warm up about 5 minutes.



6. Block ambient light from the flow tube entrances and record and save about 5 minutes of data. Examine the data in a spreadsheet. At one second binning (2 samples) the data should maintain a standard deviation of  $0.002 \text{ m}^{-1}$  or less above 450 nm. If there is a substantial slope to the data over the acquisition period the sensor may have some residual moisture in the flow tubes or on the windows. If the optical path isn't getting dry, use a small flow of dry nitrogen through the tubes while sampling.
7. Remove the flow tube and re-clean the windows. The single wipe technique with ethanol will work fine at this point.
8. Repeat steps 4–6 until mean values stabilize over three cycles. Use these values as air calibration values.

### 1.5 Cleaning

1. Remove flow tubes and all O-rings. Remove the sleeves from the flow tubes. Wash the windows with a mild detergent diluted with distilled, reverse osmosis-filtered (RO) or de-ionized (DI) water and rinse the flow tubes. Use Kimwipes or other lint-free tissues to wash the windows. Rinse the sensor off completely with water to ensure no soap residue is left inside the flow tubes or on the windows.
2. Dry the sensor. Place the sensor in a protected area where it can dry completely. Using a small heater to blow warm air over the sensor may help speed the process. Using dry nitrogen to blow-dry the sensor and remove water from the small grooves around the windows will also help speed the process. The sensor should be left overnight to dry completely. Reassemble the sensor. Carefully replace O-rings and flow sleeves back on to the flow tubes. Replace O-rings around the windows.
3. Put a couple of drops of methanol or ethanol on a Kimwipe or lint-free tissue. With firm pressure, gently wipe the windows with the dampened tissue. This should remove any visible streaks on the windows. If necessary, follow with a dry wipe in one direction across the window face. Blow off any lint or dust with a dry air source.
4. Clean the flow tubes by putting a few drops of methanol on a Kimwipe and, using a slim ( $\sim 1/4''$ ) wooden or plastic rod, **carefully** slide the Kimwipe through the flow tube. Repeat this procedure on the second flow tube. Make sure there are no streaks or small pieces of lint left on the inside of the flow tube.
5. Dry the windows. Small amounts of moisture can affect the air readings, so make sure the sensor is completely dry. Use nitrogen to dry the windows immediately before replacing the flow tubes. This will remove any water or methanol trapped in the small grooves around the window.
6. Replace the flow tubes. Carefully slide the flow tubes into place without sliding dirt across the windows. Slide the sleeves up around the windows and over the O-rings. Make sure they are firmly in place and aligned correctly. Use small black



---

caps, or black electrical tape, over each of the nozzles on the flow sleeves to provide a dark environment and to keep the sensor clean and free of moisture while collecting data.

7. Supply power to the sensor and allow it to operate for at least 15 minutes to allow the sensor to equilibrate to the ambient air temperature. Data that is collected after the sensor has equilibrated should not vary more than  $0.005 \text{ m}^{-1}$  per wavelength. If necessary, repeat steps 4–6 until the average data value varies by less than  $0.005 \text{ m}^{-1}$ .
8. When operating the ac-s in warm ambient air (e.g.  $> 25 \text{ }^\circ\text{C}$ ) environments, it is advisable to place the sensor in a shallow pan of water (immerse most of the lower pressure housing) to help keep it cool. Using WETView, monitor the ac-s internal temperature to insure it is operating within its specified temperature range. Refer to the sensor's calibration page for the specific range of internal temperatures for which the sensor is calibrated. If the sensor's internal temperature is higher than the maximum calibration range, it may be operating out of specification.
9. Repeat this process until the air values are within specification.
10. Perform the air calibration procedure again at the end of a cruise or data collection period to track the instrument's performance over time.

**Note**

The ac-s time averages its dark offsets. If the flow tubes are removed during recording of a data file, the incoming light may corrupt the dark readings. Should this occur, replace the flow tubes and either wait three minutes for the dark offsets to stabilize, or cycle the power to the sensor, resetting the dark offsets.

---

**Commented [A1]:** This makes little sense, collect the data for 10 minutes and then collect again??



## 1.6 System Requirements

This section explains the basic system components necessary to operate the ac-s. Components will depend on whether the ac-s is used for profiling, on a mooring, or underway flow.

Equipment	Function
<i>Sensor</i>	The ac-s is the basic optical sensor.
<i>Pump</i>	The flow-through system will typically require an ancillary pump to assure proper operation. Pump requirements depend upon desired flow rates, required depth of operation, power availability, and existing hardware.
<i>Cabling</i>	The ac-s requires three conductors for power and RS-232 output.
<i>Power Supply</i>	The ac-s requires a 10–35 VDC supply, capable of providing a minimum of 10 watts continuous output. Additional wattage will be required to also drive a pump from the same supply. If a longer cable is used, power losses must be accounted for in determining the power supply voltage and power requirements.
<i>Serial Communications</i>	Data from the ac-s is transmitted via RS-232. The host PC or data logger must have a serial interface capable of accepting data from the sensor at a rate of 115,200 baud. Use a PC with standard RS-232 or USB communication ports.
<i>Host/Data Logger</i>	The ac-s can be connected to any PC or data logger capable of supporting a 115,200 baud rate serial interface.
<i>Software</i>	WETView host software interfaces directly to the ac-s via the PC serial port. It allows real-time graphical visualization of the data being collected and automatically applies calibration constants, temperature corrections and generates a tab-delimited ASCII text file that can be imported into programs such as MS® Excel or MatLab® for post-processing or manipulation.

Commented [A2]: I don't get this?

Commented [A3]: Do these need the trademark symbols?



## 2. Operation

### 2.1 Basic Power On

1. **Check cable wiring.** Make sure the “+” and “-“ leads of the test cable are connected to the corresponding leads of a power supply. Make sure that the power supply provides between 10 and 35 VDC, and is rated for at least 2 amps.

#### **WARNING!**

**Power input on the ac-s is diode-protected against reverse polarity. However, this will not protect the sensor from input voltages that exceed the maximum input specification (35 VDC).**

---

2. **Cable connections.** The surface (dry) end of the cable should have terminations for an RS-232 connection into the computer and leads that connect to a power supply. Attach the power leads to a stable power source that supplies 10–35 VDC to the ac-s. Make sure the polarity is correct before switching on the power supply. Connect the RS-232 connector to the desired serial port of the data collection computer. Plug the sensor connector end of the cable into the ac-s. Use a small amount of pure silicone spray to lubricate the connectors. **Do NOT use silicone grease or WD-40.** Secure the connector lock collar to each connection.
3. **Turn on power supply.** To verify basic operation when not connected directly to a computer, remove one of the flow tubes and, in a darkened environment, place a white piece of paper into the beam path. The beam image will show on the piece of paper. Listen for a faint whirring noise from the motor in the lower pressure housing. If there is no noise or visible beam, the sensor is not working. Check the connections and the power supply. If the sensor still does not operate, contact WET Labs for technical assistance.
4. **For optimum stability allow the sensor to warm up for 3–5 minutes before collecting data.** While this is not an absolute requirement, the instrument’s electro-optics are subject to an initial stabilization period.

### 2.2 Mounting and Deployment

ac-s operation is optimized for a vertical to forty-five degrees off-vertical orientation with the bulkhead to provide the proper pump priming and to avoid trapping air bubbles in the flow tubes. Put the system at a depth of 20 meters and allow the required in-water warm up period to occur at depth. This helps the pump to prime properly and compresses small air bubbles, allowing them to be expelled from the sensor.

While operation of the ac-s in a horizontal orientation is possible, WET Labs recommends that both air and water calibrations be done in the orientation in which the sensor will be deployed to obtain the best results.

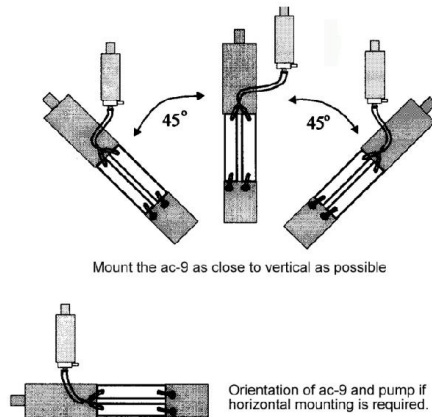
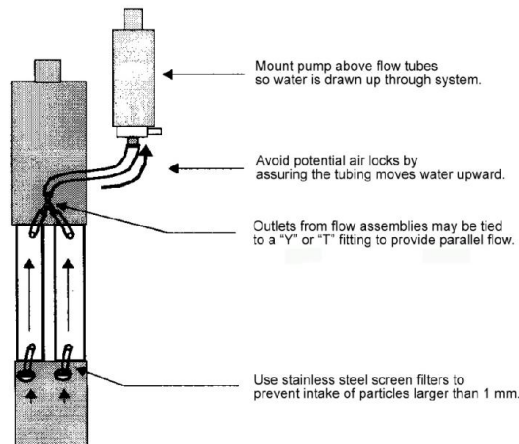

**Figure 1.** ac-s mounting positions

Specific mounting instructions will depend upon your implementation of the sensor. To assure long term sensor integrity and optimum operation, observe the following basic procedures:

1. **Do not make direct contact between the ac-s pressure housing and a metal frame or hose clamp.** The ac-s is available in one of two pressure-housing materials. Titanium is used for full ocean depth rated sensors and a combination of acetal copolymer plastic and aluminum is used for the standard models rated to 500 meters. WET Labs recommends putting a neoprene spacer between the sensor and its frame or clamp. At the very least, any contact area should be taped carefully to assure mechanical and electrical isolation.
2. **Do not apply torsional stress to the sensor housing.** The optical path is encased in a rigid housing, but is still subject to distortion if the sensor is subjected to undue stress. The sensor has a delicate optical path that is subject to misalignment if stress is applied unevenly to the upper and lower cans. Make sure the sensor is mounted on at least two points and that neither point is a stress point.
3. Make sure the sensor has an unobstructed upward flow through the flow chambers and the pump (Figure 2).

Commented [A4]: Isn't this now Ti



**Figure 2.** Proper connection of ac-s flow tube

Tips to get optimal data from the ac-s:

- ✓ Use a sturdy container (such as the WET Labs-supplied shipping crate) to transport the sensor to the field. The optics are extremely sensitive and can be jarred out of alignment when subjected to shock.
- ✓ The data will be adversely influenced by bubbles, dirt or grease in the flow path or misalignment of the flow tubes. Make sure that the flow tubes, pump tubing and screens are free of dirt and grease. Clean with ethanol or warm soapy water. Rinse with clean tap or distilled water. Do not allow water to dry on the windows as this will leave a residue that may be hard to remove.
- ✓ Always check to insure that the flow tubes are installed properly and are installed on the appropriate absorption and attenuation locations.
- ✓ Secure the ac-s to a sturdy cage or lowering frame that will protect the sensor from striking the deck, ship's side, or sea bed. Use a dielectric isolator (rubber sheeting or thick tape) to isolate the sensor's pressure housing from the steel cage.
- ✓ When clamping the sensor to the cage, make sure no torsional stresses are applied. Even slight wracking of the sensor can alter the beam alignment. This will severely degrade the data quality, especially on the 'c' side, which requires an extremely tight alignment tolerance.
- ✓ Once every couple of days, take a data file in air to track any sensor drift. The sensor must be very clean and completely dry to achieve an accurate air calibration measurement. Using compressed dry nitrogen or oil-free dry air to blow the instrument's flow tubes and windows dry will speed the drying process.



- ✓ Upon deployment, the sensor should be lowered to just below the water's surface. Turn on the sensor and pump and check to ensure that the pump has primed and is operating properly. Lower the package to a depth of 10–20 meters. Run the sensor for 3–5 minutes to allow the motor controller to stabilize, the flow tubes to clear and the sensor to begin to equilibrate with the water temperature.
- ✓ After the warm up period, raise the package to just below the surface and begin data collection. The initial depth will be dependent on the natural surface conditions and the amount of bubbles that the ship itself is generating. Steadily lower the cage through the water column.
- ✓ The upcast can proceed immediately after the downcast. It is your choice whether to open a new data file for the upcast or include the down and upcast data in a single file.
- ✓ Once the cage is back to the just below the surface, stop the data collection and turn off the pump. Carefully bring the cage on deck and lash it down. Give the cage and sensor a fresh water rinse after every cast. If this is not practical, wash the sensor at the end of each data collection day. Hold a hose (at low pressure) over the pump discharge port to flush the tubing and the flow tubes. Rinse the flanges and connectors. If leaving the sensor on deck for more than a few minutes, cover the cage with a tarp to avoid over-heating from solar insolation. At the end of each data collection day, remove the tubes and carefully clean and dry both the flow tubes and windows. Failure to flush the sensor with fresh water may cause corrosion damage over time.

### 2.3 Data Collection

WET Labs offers several output configuration options to provide flexible interfacing to different systems. These various output protocols are discussed at length in the Data Processing Section of the manual. When turned on, the sensor automatically begins to collect data and outputs that data in its appropriate format. The sensor uses RS-232 output operating at 115,200 baud. Data from the sensor is binary.

### 2.4 Care and Maintenance

Clean the sensor after a field deployment before storing it. Refer to [Section 1.5](#) for detailed cleaning procedures. The following steps will help prolong the life of the sensor:

1. **Rinse the pressure housing.** If a dummy plug for the connector is available, install it on the main bulkhead connector before flushing the sensor. Begin with a thorough rinsing of the sensor and its flow tubes with fresh water. After rinsing, towel-dry the pressure housing and remove the flow tubes.

#### **WARNING!**

**Do not use acetone on the windows. It will damage the window holders.**





2. **Wash the windows.** The windows should be cleaned with dilute soapy water, followed by ethyl alcohol, and should receive a final rinse with distilled or reverse osmosis-filtered water. This will remove any fingerprint oil, grease or other contaminants from the windows. Use lint free lens cleaning paper to avoid scratching the windows or detectors.
3. **Wash the flow tubes.** To clean the absorption path's reflective tube, carefully plunge an alcohol-soaked tissue through the tube and rinse thoroughly with distilled water. Whenever plunging a tissue through the tube, use a wooden or plastic dowel to prevent scratching the sides of the tube. After rinsing, dry the tube either by blowing dry nitrogen through it or by plunging a soft tissue. The attenuation path flow tube is virtually maintenance free, except for occasional cleaning. Follow the same basic procedures supplied for cleaning the absorption path tube. Remove the flow tube sleeves when drying the flow tubes.
4. **Store the sensor.** Store and transport the ac-s in a shock-protected environment. Use the original packaging from the manufacturer to safely transport the sensor, providing it is handled in a reasonably careful fashion.

### 3. Data Processing

Data from the ac-s is acquired and processed through the following steps.

#### 3.1 Analog Acquisition

Optical radiation at the reference and signal channels is continuously monitored by operational amplifiers operating in a current to voltage configuration. The amplifiers are configured for a gain of approximately  $10^7$  for the reference channels and approximately  $2 * 10^6$  for the signal channels.

#### 3.2 Analog-to-Digital Conversion

The A/D used in the ac-s supports six input channels that are triggered pair wise. Four channels are dedicated to the attenuation beam reference and signal channels and the absorption beam reference and signal channels. Another channel is dedicated to the output of the optional pressure sensor amplifier. The sixth channel is preceded by an 8 channel analog mux and is used to sample ancillary analog signals including the internal and external temperatures via thermistors within the unit. Ancillary signals are sampled during the "dark" periods when the beams are not passing through the optical filters.

#### 3.3 Digital Processing and Data Output

The CPU takes multiple samples of both signal and reference channels, accumulates them through the sampling period, and then averages the values at the end of the sampling period. Once averaged, light and dark values are collected for each channel. The CPU takes the difference of these values to derive its output value. Once signal data is accumulated, its output is transmitted through the RS-232 port. For a more detailed explanation, see Section 6.4, Signal Processing.



### 3.4 Data Format

The ac-s outputs data in binary format. If you will not be collecting the data using WETView, your collection system will need to be able to handle binary data. Beware that some serial port terminal programs such as HyperTerminal are not capable of capturing true binary data streams. HyperTerminal, for example, fails to capture ASCII NULL characters (hex 00). WETView is capable of processing collected binary files in addition to serial data. If you prefer to use your own software to process the ac-s output data, please refer to Appendix A for a description of the ac-s data packet formatting.

### 3.5 Post Processing

Once accumulated by a host computer, the data must be post processed to yield meaningful scientific data.

The primary transfer equation for yielding the attenuation coefficient, **c**, or the absorption coefficient, **a**, for a given wavelength is:

$$Tr = e^{-cx} \quad (1)$$

Where Tr is the transmittance, c is the attenuation coefficient, and x is the pathlength of the water volume being measured. The following treatment applies to the absorption case if **c** is replaced by **a**. The pathlength of the ac-s is fixed at either 25 cm or 10 cm depending on which version you have. In the case of the ac-s the transmittance is computed by taking the ratio of the signal value to the reference value:

$$Tr = (C_{sig}/C_{ref}) / N \quad (2)$$

Substituting equation (2) into equation (1) we get:

$$(C_{sig}/C_{ref}) / N = e^{-cx}, \quad (3)$$

Where  $C_{sig}$  and  $C_{ref}$  are the signal and reference count values from the sensor and N is a sensor specific calibration constant obtained in the laboratory using clean water. For more information about how N is derived, see Section 4, Calibration.

We therefore can solve for **c** (or **a**) by:

$$c = -1/x [\ln(C_{sig}/C_{ref}) - \ln(N)] \quad (4)$$

$$\text{or } c = -1/x (\ln(C_{sig}/C_{ref})) - (-1/x (\ln(N))) \quad (5)$$

$$\text{or } c = [(\ln(N)/x) - (\ln(C_{sig}/C_{ref})/x)] \quad (6)$$

The ac-s pathlength is a fixed constant (typically at 25 cm) and can be found in the device file. The determination of  $(\ln(N)/x)$  is needed to accurately measure **c**. This value is derived for each channel and is supplied with each sensor's calibration data sheet as the "Water Offset" value and is referred to as  $c_{off}$  in equation (8).

**Commented [A5]:** Is this document intended for the 10cm pathlength version as well? If so, we need to note that.



The temperature correction is applied using the sensor's internal temperature from the reference line and the correction table from either the Calibration Sheet or the Device File. The approximate correction value is linearly interpolated from the table. First, the correct temperature bin is determined by finding the two bin temperatures,  $T_0$  and  $T_1$ , that bracket the current instrument internal temperature. Then, using the values,  $\Delta_{T_n}$  and  $\Delta_{T_{n+1}}$ , from the table, we obtain:

$$\Delta_T = \Delta_{T_n} + \frac{(T - T_0)}{(T_1 - T_0)} * (\Delta_{T_{n+1}} - \Delta_{T_n}) \quad (7)$$

Where:

- $\Delta_T$  = compensation constant
- $T$  = current temperature
- $T_0$  = first bin temperature
- $T_1$  = second bin temperature
- $\Delta_{T_n}$  = first value
- $\Delta_{T_{n+1}}$  = second value

This temperature correction is automatically applied by the WETView software. To manually process the raw data stream, apply this correction to arrive at the temperature-corrected absorption and attenuation coefficients.

WETView reads in the raw binary data and applies an algorithm that—

1. Computes uncorrected engineering units (in inverse meters) from the signal and reference values.
2. Applies a linear temperature correction (for the meter's internal temperature) using constants supplied in the instrument's device file.
3. Applies clean water offsets supplied from the instrument's device file that provide a value referenced against clean water.

Combining these steps into one formula:

$$c(\lambda) = (c_{\text{off}} - 1/x [\ln(C_{\text{sig}} / C_{\text{ref}})]) - \Delta_T \quad (8)$$

and:

$$a(\lambda) = (a_{\text{off}} - 1/x [\ln(A_{\text{sig}} / A_{\text{ref}})]) - \Delta_T$$

where:

$c(\lambda)$ , $a(\lambda)$	is the attenuation coefficient and absorption coefficient, respectively in $\text{m}^{-1}$
$c_{\text{off}}$ , $a_{\text{off}}$	is the water offset value (provided on the Calibration Sheet) in $\text{m}^{-1}$
$C_{\text{sig}}$ , $A_{\text{sig}}$	is the measured amount of light (power) that reaches the receiver detector from the ac-s data stream in raw digital counts
$C_{\text{ref}}$ , $A_{\text{ref}}$	is the amount of light (power) measured by the reference detector from the ac-s data stream in raw digital counts
$x$	is the sample volume path-length in meters
$\Delta_T$	is the internal temperature compensation correction value in $\text{m}^{-1}$ derived from Equation (8).



### 3.6 Temperature and Salinity Correction

Before ac-s data can be corrected for temperature and salinity, the data must be merged with CTD data and the time lags must be corrected.

Since the ac-s measurements are referenced to clean water, the measured absorption and attenuation coefficients,  $a_m$  and  $c_m$ , represent the absorption and attenuation of all the material in the sample,  $a_t$  and  $c_t$ , minus water:

$$a_m = a_t - a_w \quad c_m = c_t - c_w$$

The temperature and salinity corrections discussed here are different than the temperature corrections discussed in the calibration section. These corrections relate to physical changes in the absorption and attenuation coefficients of pure water,  $a_w$  and  $c_w$ , due to changing dissolved salt content and temperature. Since the water calibration “blank” was carried out with optically clean fresh water, the effects of salt in a seawater sample on the absorption and attenuation of pure water must be removed. Note that the absorption and attenuation from the specific salts in seawater are negligible, i.e., the signal is lower than the precision of measurements; the observed effect relates to the changing absorption and attenuation of pure water due to altered molecular interactions in the presence of dissolved salts. Similarly, a water calibration is carried out at an arbitrary temperature that is likely different than the temperature of the water sample; the effective change in pure water absorption resulting from this difference in temperature should be removed. Note that not all portions of the absorption and attenuation spectra in the visible range are affected by temperature and salinity. The temperature and salinity effects are largest in the near infrared and reduce to undetectable in the visible.

Temperature and salinity effects on pure water absorption and attenuation can be removed using the algorithm:

$$a_{mts} = a_m - [\Psi_t * (t - t_r) + \Psi_{sa} * S]$$
$$c_{mts} = c_m - [\Psi_t * (t - t_r) + \Psi_{sc} * S]$$

where  $t$  and  $t_r$  are in-situ and reference temperatures, respectively, and  $S$  is salinity. Refer to the ac Protocol Document for the values for  $\Psi_T$  (Table 2), and the values for  $\Psi_{Sa}$  and  $\Psi_{Sc}$  (Table 3). Note that changes in temperature affect absorption and attenuation the same (their effect on pure water scattering from temperature is negligible).

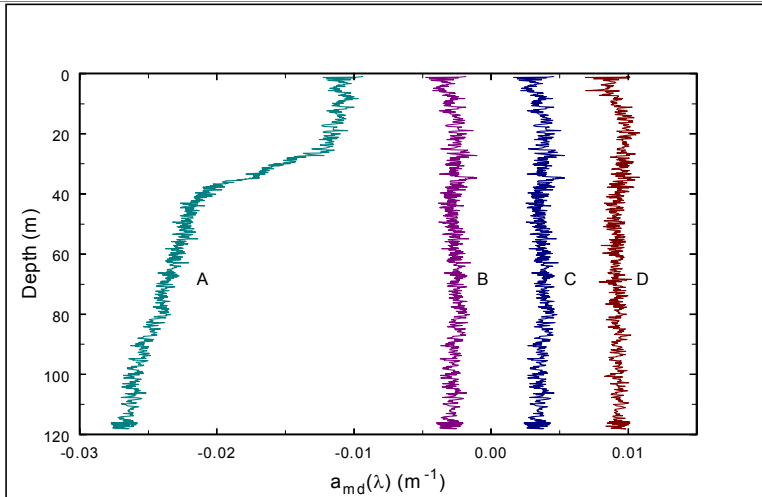

**Figure 3.** The application of temperature and salinity corrections to a Gelbstoff profile.

In the example provided in Figure 3, line A is the raw  $a(715)$ . Line B has the temperature correction applied. Line C includes the temperature and salinity corrections. Line D is the absorption coefficient at 650 nm, given to provide a reference profile. Note that both temperature and salinity corrections are necessary to provide a profile with positive absorption values in this case. Also note that other corrections such as the sensor drift and reflective tube scattering correction have not been applied.

**Note**

WETView does not perform this water-based absorption temperature correction.

**3.7 Reflective Tube Scattering Correction**

Reflecting tube absorption meters (and spectrophotometers in general) do not collect all of the light scattered from the source beam. The uncollected scattered light, also known as the scattering error and nominally comprised of the light scattered from ~41 to 180 degrees when using a quartz tube, causes the sensor to overestimate the absorption coefficient. There are several schemes to correct absorption measurements for scattering errors. Note that the data at this point should have already had the temperature and salinity correction and the sensor drift correction applied. The three most commonly used scattering corrections include:

1. Subtraction of data at a reference wavelength where the absorption is assumed to be zero.
2. Removal of a fixed proportion of the scattering coefficient, computed by subtracting absorption from attenuation.

3. Use of a reference wavelength to determine the proportion of the scattering coefficient to be subtracted from the signal. Scattering is computed by subtracting absorption from attenuation.

Each of these methods requires different assumptions and ancillary measurements.

The first method to correct for scattering errors is to subtract the absorption measurement at a reference wavelength. It is assumed that at the reference wavelength the absorption by particulate and dissolved materials is negligible, so that the measured absorption signal is caused strictly by the scattering error. It is further assumed that the shape and magnitude of the volume scattering function is independent of wavelength. Commonly, the reference wavelength selected is in the near infrared portion (715 nm on an ac-9) of the spectrum. In very clean water, where absorption at 715 nm may be close enough to zero to generate negative values from normal noise fluctuations (near  $0.001 \text{ m}^{-1}$ ), it is advisable to subtract zero instead of a negative  $a_{715}$  value, as the latter leads to positively biasing absorption at the other wavelengths. Some bin averaging can also be carried out to reduce small noise fluctuations in this case.

The second method assumes that the scattering correction is a fixed proportion,  $\epsilon$ , of the scattering coefficient  $b(\lambda)$ . Note that  $b(\lambda)$  is obtained from  $c(\lambda) - a(\lambda)$ .

A value of  $\sim 0.14$  has been suggested for  $\epsilon$  for waters where biological particles dominate scattering. A value of  $\sim 0.18$  has been suggested for  $\epsilon$  when sediments dominate the scattering. These values of  $\epsilon$  are empirically derived from field data and the third scattering correction technique as well as being modeled by Kirk (1993). Since the measured absorption has the small error we are trying to correct for here, the estimated scattering coefficient is not equal to the true scattering coefficient, so  $\epsilon$  is slightly larger than models would predict. This method assumes that the shape of the volume scattering function is independent of wavelength and type of material. The magnitude of the scattering correction is, however, allowed to vary with wavelength. Since a reference wavelength is not used there is no requirement that the absorption coefficient equal zero at the reference wavelength.

The third method to correct the scattering error is a combination of the first two techniques. It is assumed that there exists a reference wavelength at which the absorption coefficient of particulate and dissolved materials is negligible. It is further assumed that the shape of the volume scattering function is independent of wavelength. The correction technique is written as:

$$a_t(\lambda) - a_w(\lambda) = a_{\text{mfs}}(\lambda) - \frac{a_{\text{mfs}}(\lambda_{\text{ref}})}{[c_{\text{mfs}}(\lambda_{\text{ref}}) - a_{\text{mfs}}(\lambda_{\text{ref}})]} * [c_{\text{mfs}}(\lambda) - a_{\text{mfs}}(\lambda)].$$

This technique allows for automatic changes in the scattering correction magnitude with wavelength and changes in types of materials present. It requires the largest number of ancillary measurements (two attenuation values, two absorption values, temperature, salinity, and calibration water temperature and salinity) which makes



this technique the most difficult to do correctly. However, if the assumptions are correct, it is the most accurate of the techniques. A consideration in applying this correction scheme is that natural fluctuations in these independent signals can introduce bias errors in the product. For example, the absorption and attenuation measurements are made simultaneously, but in different water samples. At any one instant, a large particle substantially perturbing a signal may be present in one sample volume, but not the other. These errors can be minimized with appropriate binning.

Note that in coastal waters where the concentration of CDOM dominates the total absorption spectrum (dissolved absorption is an order of magnitude greater than the particulate absorption), care should be taken in applying a scattering correction. In this case, it is best to remove the dissolved fraction from the total absorption spectrum (i.e. compute particulate absorption fraction), and then apply the scattering correction.

#### 4. Manufacturer's Calibration

The ac-s is a dual path absorption and attenuation sensor whose output values are related to a specific reference medium: Nanopure clean water at 18.2 megohms at room temperature at atmospheric pressure. The sensor is calibrated to provide a reading of 0.0 for all channels in clean fresh water. The offset value, determined during the manufacturer's calibration process, is referred to as "N" in the preceding sections. This is an important consideration for users who want to compare data from other sensors that do not read 0.0 in clean water. Therefore, the final output of the WETView software is the absorption and attenuation with clean water attenuation subtracted.

##### 4.1 Temperature Correction

Beyond confirming basic sensor operation and alignment, temperature corrections are the first tests performed on the sensor. Temperature corrections are requisite to all other tests. Corrections are performed using WETView. WETView employs a correction algorithm that uses multiple offset values,  $\Delta T_n$  values obtained by measuring output differences over small temperature increments. Sensor values are collected and averaged every one half to one degree Celsius through the operational temperature range of the sensor. From these values we generate a table of temperature compensation offsets  $[\Delta T_n]$ . This table is contained in each instrument's device file. Using the table, WETView then applies the algorithm  $[a' = a_{raw} - \Delta T_n]$  for given temperatures in the table. For temperatures that fall between table values, the program applies a linear interpolation upon the data for further correction. By using this scheme, we can thus effectively compensate for non-linear changes due to temperature in the instruments' output. For a description of this algorithm please refer to section 3.5, Post Processing.



#### 4.2 Precision

Precision is determined by running the sensor for an interval of time (approximately 20 minutes) and determining the standard deviation of the signal at each wavelength for at least 100 samples. The manufacturer performs this measurement in air. With one-second binning of the signals, minimum performance is  $0.012 \text{ m}^{-1}$  for wavelengths below 450 nm and  $0.003 \text{ m}^{-1}$  for wavelengths 450 and above.

Both air and water measurements can be difficult to perform. If running the tests in air, make sure that the flow tubes, windows and O-rings are completely clean and dry. Do not allow any ambient light penetration into the cells. Use the supplied caps or black tape to seal the flow tube nozzle openings.

When operating the sensor in water, use clean water, free of bubbles, and do not exceed flow rates of 1–2 liters per minute.

#### 4.3 Absolute Calibration

Absolute calibration of any underwater optical absorption or attenuation sensor is difficult as there are no readily available absolute standards. Pure water is difficult to obtain, unstable once it is made, and its absolute optical properties are not well known. Nevertheless, pure water is the baseline for all oceanic property measurements.

A qualitative but surprisingly accurate test of water purity can readily be obtained using a beaker and a small laser in a darkened room. Shine a pointing laser (such as those used for lectures and presentations) through the water and view it slightly off axis to the impinging beam. Scatterers will be readily detected. Try this first with some tap water. It will show you what to look for. Do not look directly into the beam, and **do not** try this test with a high power laser. If there are more than one or two large scatterers in the beam path, the water is unsuitable for a clean water calibration.

#### 4.4 Linearity and Dynamic Range

To determine linearity of the absorption and attenuation detection systems, varying concentrations of scattering agent are applied and plotted apparent “a” and “c.” Typically linearity in “c” throughout the dynamic range is extremely high with a regression coefficient of 0.9999. Linearity in “a” exceeds 0.998.

#### 4.5 Air Calibration and Tracking

During the factory calibration, clean water values are obtained and used to correct the meter’s output. The meter is thoroughly dried and its air values recorded. These air values represent the effective measurement of air for a calibrated instrument and are supplied on the calibration page that is shipped with each sensor.



## 5. Specifications

Mechanical		Optical	
<b>Diameter, cm</b>		<b>Spectral range</b>	400–730 nm
Standard	10.4	<b>Bandpass (FWHM), nm</b>	
5000	9.9	400	10–18
<b>Length, cm</b>		450	10–16
Standard	79	550	10–15
5000	75.79	650	10–18
<b>Weight in air, kg</b>		730	10–25
Standard	5.9	<b>Pathlength, cm</b>	
5000	9.75	Standard	10 or 25
<b>Weight in water, kg</b>		5000	25
Standard	0.80	<b>Beam cross-section</b>	8 mm dia. (nominal)
5000	4.5	<b>Linear dispersion</b>	6–7.0 nm/mm
<b>Pressure housing</b>		<b>Linearity</b>	≥ 99% R <sup>2</sup>
Standard	Acetal copolymer	<b>Resolution</b>	4 nm
5000	Titanium 3-2	<b>Precision</b>	
		(400–449 nm)	+/-0.003 m <sup>-1</sup> typ., 0.006 m <sup>-1</sup> max @ 1 Hz +/-0.005 m <sup>-1</sup> typ., 0.012 m <sup>-1</sup> max @ 4 Hz
		(450–730 nm)	+/-0.0005 m <sup>-1</sup> typ., 0.0015 m <sup>-1</sup> max @ 1 Hz +/-0.001 m <sup>-1</sup> typ., 0.003 m <sup>-1</sup> max @ 4 Hz
		<b>Accuracy<sup>1</sup></b>	+/-0.01 m <sup>-1</sup>
		<b>Dynamic range</b>	0.001–10 m <sup>-1</sup>
Electrical			
<b>Input</b>	10–35 VDC		
<b>Current draw</b>	0.83 A @ 12 V nominal		
<b>Serial output</b>	RS-232		
<b>Connector</b>	MCBH6M		
<b>Sample rate</b>	4 scans/sec., nominal		
Environmental			
<b>Depth rating, m</b>			
Standard	500		
5000	5000		
<b>Temperature range, operational</b>	0–30 °C		
<b>Temperature range, storage</b>	-20–50 °C		

<sup>1</sup> Measured with Nanopure water at 18.2 megaohms at room temperature at atmospheric pressure.

*Specifications are subject to change without notice.*

### 5.1 Connectors

The ac-s has two bulkhead connectors. The power and data connector has six pins and connects to the sea or test cable. A second connector with three sockets provides power to the pump. Contact numbers are molded into the rubber bodies of the plugs.

Pin	Function
1	Ground
2	RS-232 (RX)
3	N/C
4	V in (10–15 VDC)
5	RS-232 (TX)
6	N/C

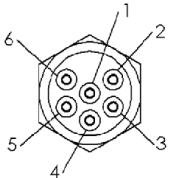



Voltage supplied to the sensor is internally jumpered to provide power output to the pump port connector. Power is applied to the pump connector whenever the sensor is powered.

**WARNING**

**Always put a pump plug or dummy plug in the bulkhead connector for the pump.**

**If the sensor is deployed without a plug in the pump bulkhead connector, the socket contacts will suffer rapid corrosion. Eventually, the corrosion could travel through the connector, causing the sensor to flood.**

Socket	Function
1	Common
2	Power Output (10–15 VDC)
3	N/C

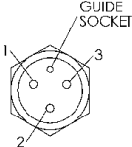



## 6. Technical Reference

### 6.1 Mechanical

The flow tube assemblies are integral to the optical behavior of the ac-s. They are optical components that help produce a very precise measurement. Inspect both tubes and make sure they are free of stains and dust before deployment. The reflective flow tube for the absorption measurement operates using the principle of internal reflection. To maintain its reflective properties, it requires a thin air gap between the outer wall of the quartz tube and the inner wall of the surrounding sleeve. The reflective tube should be periodically checked for leaks. To determine if the tube is maintaining its reflective properties, immerse it in water and point towards a fairly light background. The inside of the tube should appear uniformly bright. If the tube has leaked, call the factory for repair instructions or tube replacement.

### 6.2 Optics

The ac-s performs concurrent measurements of the water's attenuation and absorption characteristics by incorporating a dual path optical configuration in a single sensor. Each path contains its own source, optics, and detectors appropriate to the given measurement. The two paths share a common filter, control and acquisition electronics. For purposes of description, we refer to the beam performing the attenuation measurement as the **c beam** and the beam used to make the absorption measurement as the **a beam**.

### 6.3 Electronics

The main electronic components of the ac-s consist of a power and i/o (input/output) board, a microprocessor board, an A/D board, an amplifier board, a motor controller board, a dc motor with an integrated position encoder, two incandescent lamps and four photodiode detectors.

### 6.4 Signal Processing

The purpose of the ac-s signal processing circuitry is to take a raw optical signal and make it into a physically meaningful measurement ready for output. Signals from the absorption path and attenuation path detectors go through several levels of analog and digital processing before they are registered as output from the unit.

## Appendix A: Data Record Format

The ac-s outputs its data as binary records. Data coming into a terminal emulator program will appear as seemingly random characters. Table 1 shows a sample hexadecimal snapshot of binary data collected from an ac-s. The leftmost column and header rows in are for reference only, and do not appear in the output data. Table 2 shows the breakout of each field within the data record. Note: Make sure that your data collection program is capable of reading a binary bit stream.



**Table 1. Sample ac-s Data Record**

row offset	0	1	2	3	4	5	6	7	8	9	a	b	c	d	e	f
000:	53	d0	03	01	53	00	00	02	4e	1e	01	ba	21	29	35	ff
010:	00	ff	00	02	d0	05	01	53	00	00	02	4e	1a	01	ba	02
020:	a1	7a	e4	b9	d7	01	d5	02	b0	00	07	1b	02	01	56	04
030:	05	03	63	04	f4	03	10	04	98	03	da	05	ab	03	ac	05
040:	3b	04	69	06	7c	04	77	05	f5	04	fe	07	67	05	52	06
050:	c6	05	ae	08	69	06	4a	07	9f	06	66	09	88	07	3a	08
060:	96	07	33	0a	c9	08	47	09	ab	08	1b	0c	32	09	6a	0a
070:	dc	09	0e	0d	c7	0a	a8	0c	2f	0a	2f	0f	84	0c	0f	0d
080:	9a	0b	5c	11	63	0d	9a	0f	23	0c	9d	13	69	0f	3a	10
090:	c5	0d	f8	15	8d	11	01	12	70	0f	5b	17	c9	12	d8	14
0a0:	32	10	ce	1a	25	14	d2	16	17	12	61	1c	b5	16	e8	18
0b0:	20	14	08	1f	85	19	2b	1a	5b	15	e7	22	8e	1b	ad	1c
0c0:	be	17	d8	25	c7	1e	5d	1f	3d	19	ef	29	33	21	3b	21
0d0:	e4	1c	17	2c	d5	24	48	24	b4	1e	6f	30	ad	27	7f	27
0e0:	9f	20	de	34	b9	2a	f7	2a	b6	23	65	38	f3	2e	8e	2d
0f0:	e7	26	0b	3d	4e	32	5d	31	29	28	c6	41	d1	36	49	34
100:	84	2b	82	46	63	3a	4f	37	d9	2e	49	4a	f4	3e	6a	3b
110:	3b	31	17	4f	b2	42	96	3e	bc	34	09	54	a0	46	f8	42
120:	6a	37	22	59	d2	4b	90	46	4e	3a	6c	5f	5a	50	7d	4a
130:	75	3d	ea	65	44	55	ba	4e	f0	41	b3	6b	9a	5b	67	53
140:	a2	45	b5	72	35	61	6f	58	73	49	be	78	df	67	9b	5d
150:	41	4d	cb	7f	79	6d	d1	61	e2	51	ab	85	d7	73	ed	66
160:	64	55	77	8c	10	79	f4	6a	be	59	19	92	12	7f	cd	6e
170:	ef	5c	a0	97	d4	85	7d	72	eb	60	01	9d	63	8b	00	76
180:	c2	63	41	a2	bd	90	5e	7a	22	67	e0	a7	92	98	2f	7d
190:	b7	6a	c6	ac	8c	9d	1a	81	13	6d	75	b1	37	a1	cc	84
1a0:	35	70	05	b5	aa	a6	4f	87	25	72	54	b9	bf	aa	85	89
1b0:	cd	74	63	bd	75	ae	5d	8c	20	76	2b	c0	b9	b1	d0	8e
1c0:	1e	77	95	c3	6e	b4	ce	8f	aa	78	9c	c5	93	b7	3c	90
1d0:	c0	79	3e	c7	05	b9	11	91	5e	79	8e	c7	e6	ba	63	91
1e0:	9c	79	82	c8	2d	bb	23	91	5d	79	13	c7	d9	bb	56	90
1f0:	b5	78	5b	c7	00	bb	07	8f	ac	77	2f	c5	83	ba	1e	8e
200:	28	75	c6	c3	76	b8	ab	8c	52	74	0d	c0	f8	b6	c8	8a
210:	1e	72	00	bd	e6	b4	5c	87	8e	6f	ad	ba	60	b1	6e	84
220:	a9	6d	0a	b6	5c	ad	f9	81	58	6a	07	b1	b7	a9	ee	7d
230:	9c	66	a8	ac	6e	a5	37	79	72	62	eb	a6	8b	9f	e9	74
240:	e3	5e	ec	a0	25	9a	16	70	00	5a	c2	99	56	93	db	6a
250:	ef	56	69	92	46	8d	4f	65	ba	52	0f	8b	15	86	9e	60
260:	82	4d	b2	83	db	7f	d9	5b	53	49	5e	7c	b2	79	16	56
270:	25	45	14	75	86	72	54	51	06	40	e1	6e	75	6b	b1	4c
280:	13	3c	d0	67	9d	65	3a	47	3a	38	d5	60	f1	5e	de	42
290:	89	35	02	5a	82	58	b8	3e	05	31	52	54	47	52	bf	39
2a0:	9c	2d	be	4e	3c	4c	fc	35	79	2a	70	48	9a	47	85	31
2b0:	8c	27	36	43	35	42	52	2d	c8	24	33	3e	15	3d	5c	2a
2c0:	3b	21	5a	39	39	38	a5	26	da	1e	9d	34	98	34	30	23
2d0:	b3	1c	1c	30	50	30	03	20	bb	19	bf	2c	49	2c	1c	22
2e0:	44	00	ff	00	ff	00	02	d0	03	01	53	00	00	02	4e	1e



**Table 2.** Breakout of Data Record Fields for Table 1

Byte Offset	Num Bytes	Data	Description
00f	4	ff00ff00	Packet registration
013	2	02D0	Record length of full packet (not including chksum) = 720
015	1	05	Packet Type 03 and above designates an ac-s meter
016	1	01	reserved
017	1	53	meter type—53 indicates an ac-s
018	3	000002	serial number
01b	2	4e1a	“a” reference dark counts
01d	2	01ba	pressure counts
01f	2	02a1	“a” signal dark counts
021	2	7ae4	raw external temp counts = 22.14° C
023	2	b9d7	raw internal temp counts = 17.91° C
025	2	01d5	“c” reference dark counts
027	2	02b0	“c” signal dark counts
029	4	00071b02	time in milliseconds since power up (465666 = 7.761 mins)
02d	1	01	reserved
02e	1	56	Number of output wavelengths = 86 decimal
02f	2	0405	raw cref <sub>1</sub> counts
031	2	0363	raw aref <sub>1</sub> counts
033	2	04f4	raw csig <sub>1</sub> counts
035	2	0310	raw asig <sub>1</sub> counts
037	2	0498	raw cref <sub>2</sub> counts
:			
2d7	2	20bb	raw cref <sub>86</sub> counts
2d9	2	19bf	raw aref <sub>86</sub> counts
2db	2	2c49	raw csig <sub>86</sub> counts
2dd	2	2c1c	raw asig <sub>86</sub> counts
2df	2	2244	checksum
2e1	1	00	pad byte
2e2	4	ff00ff00	start of next packet

### Primary Processing

When receiving binary packets from an ac-s, look for the four-character packet registration. The characters, in hexadecimal notation, are FF 00 FF 00. After successfully receiving these characters, the 2-byte packet length is the next item to be received. The packet length indicates the number of bytes sent in the packet, including the 4-byte packet registration. The packet length excludes the 2-byte checksum and the pad byte. The packet length varies from sensor to sensor depending on the number of output wavelengths.

The next byte is a packet type identifier used by WETView. It should be 3 or higher for the ac-s.

The next byte is reserved for future use.



The serial number is a standard four-byte long integer. The first byte of the serial number denotes the sensor type. The remaining three bytes are the binary serial number.

The two bytes following the serial number are the A reference channel dark counts. It is present mainly for diagnostic purposes.

The next two bytes are the A/D counts from an undeveloped circuit. These should be ignored.

The following 2 bytes are the A signal dark counts for diagnostic purposes.

The next two bytes represent the raw external temperature voltage counts from across a thermistor. The external temp is calculated by a polynomial that converts counts to degrees C. Calculate the temp using the polynomial:

$$y = a \times \text{counts}^3 + b \times \text{counts}^2 + c \times \text{counts} + d$$

where  $a = -7.1023317 \text{ E-13}$ ,  $b = 7.09341920 \text{ E-8}$ ,  $c = -3.87065673 \text{ E-3}$ , and  $d = 95.8241397$

The internal temperature is given as a reading from a thermistor. The manufacturer of the thermistor provides a function to convert resistance to temperature. The two byte value in the data packet represents the voltage drop across the resistor. To determine the resistance of the thermistor, first convert the counts (16 bit unsigned integer) to volts using the equation:

$$\text{volts} = (5 \times \text{counts} / 65535)$$

then convert volts to resistance:

$$\text{resistance} = 10,000 \times \text{volts} / (4.516 - \text{volts})$$

then finally convert resistance (res) to degrees C:

$$\text{temp} = \frac{1}{a + b \times \ln(\text{res}) + c \times (\ln(\text{res}))^3} - 273.15$$

where  $a = 0.00093135$ ,  $b = 0.000221631$ , and  $c = 0.000000125741$

The following 4 bytes are the C reference and signal dark counts respectively for diagnostic purposes.

Next is a four-byte unsigned integer value representing the time in milliseconds since the sensor was started up.

Following that is a one byte value that is reserved for future use.

Next is a one byte unsigned integer representing the number of output wavelengths.

Next is the data for the scan. The values are the averaged signal counts (dark count subtracted) for each detector at each output bin. The counts are 16 bit unsigned values, transmitted in the order  $C_{ref1}$ ,  $A_{ref1}$ ,  $C_{sig1}$ ,  $A_{sig1}$ ,  $C_{ref2}$ , ...,  $C_{refn}$ ,  $A_{refn}$ ,  $C_{sign}$ ,  $A_{sign}$ , where  $n$  is the number of output wavelengths. The output wavelengths are in



---

increasing wavelength order, running from approximately 400 nm to 715 nm or higher.

Following the data, at the end of the packet, a two byte checksum is sent. This checksum is the unsigned 16 bit sum of all characters sent in the packet, including the identifier (FF 00 FF 00) and up to the last data byte preceding the checksum field.

One pad character (00) is sent following the checksum, before the next packet identifier is sent.

### **Appendix B: Common Mode A/C Induced Noise**

The ac-s can be susceptible to common mode noise caused by environmental alternating current (A/C) generated electromagnetic fields. Typically, this will be caused by 60 Hz A/C power wiring in a laboratory or ship environment. This noise can cause large measurement errors in situations where the sensor does not have adequate grounding. Specifically, if a sensor is powered from a battery or another “floating” power supply and is feeding data to a laptop that is not grounded (powered via its own battery, or ungrounded A/C adapter) this common mode noise will be most apparent. To eliminate this noise issue, either the laptop, the power source, or the sensor itself needs to be connected to a ground (i.e. the ground receptacle of a wall outlet). Grounding for a power supply should be made at the negative power connection to the sensor. When grounding the sensor itself, any of the 10-24 socket cap screws on the unistrut yoke that support the zinc anodes will suffice. Grounding for a laptop can generally be done via the metal shielding around its serial port, parallel port or display connections. If an adequate earth ground is not available in a shipboard environment, a wire to sea water should suffice. When used in-situ, the distance from A/C fields and grounding of the sensor through immersion in sea-water effectively eliminates this source of noise.







## Revision History

Revision	Date	Revision Description	Originator
1	2/4/04	Draft document	B. Rhoades
A	2/10/04	New document (DCR 364)	D. Hankins, B. Rhoades
B	6/29/04	Update specifications (DCR 401)	D. Stahlke, I. Walsh
C	12/2/04	Update Appendices to reflect optional pressure sensor and common mode noise (DCR 439)	B. Rhoades
D	4/11/05	Add ac-9 Protocol Document to list of delivered items (DCR 465)	R. Watte
E	1/13/06	Clarify warranty statement (DCR 481)	A. Gellatly, S. Proctor
F	2/9/06	Correct output precision value (DCR 486)	B. Rhoades, H. Van Zee
G	2/5/08	Clarify internal temperature equations (DCR 562)	A. Barnard, J. Bell
H	5/21/08	Correct internal temperature correction equation (DCR 595)	A. Barnard, J. Bell
I	7/31/08	Correct instrument weights (DCR 607)	A. Derr, H. Van Zee, I. Walsh
J	2/9/09	Correct error in output wavelength timing	B. Rhoades
K		Correct input voltage spec and remove pressure sensor section (DCN 821)	D. Stahlke
L	4/18/13	Add deep sensor information and specs, update manual (DCN 826)	A. Barnard, J. Kogler, H. Van Zee
M	9/16/13	Remove references to RS485 and 422 (DCN 839)	J. Pearson