



SEA-BIRD
SCIENTIFIC

Product Manual

SBE 36 CTD Deck Unit & Power Data Interface Module (PDIM)



SBE 36 Deck Unit – front panel (LEDs & switch)



SBE 36 Deck Unit – back panel (connectors & fuses)

Release Date	07/31/17
Version	021
Firmware	3.0c & later
Software	Seaterm V2 2.6.3 & later Seasave V7 7.26.7 & later



Power Data Interface Module (PDIM)

service@seabird.com | support@seabird.com | Tel: +1 425 643 9866

Limited Liability Statement

Extreme care should be exercised when using or servicing this equipment. It should be used or serviced only by personnel with knowledge of and training in the use and maintenance of oceanographic electronic equipment.

SEA-BIRD ELECTRONICS, INC. disclaims all product liability risks arising from the use or servicing of this system. SEA-BIRD ELECTRONICS, INC. has no way of controlling the use of this equipment or of choosing the personnel to operate it, and therefore cannot take steps to comply with laws pertaining to product liability, including laws which impose a duty to warn the user of any dangers involved in operating this equipment. Therefore, acceptance of this system by the customer shall be conclusively deemed to include a covenant by the customer to defend, indemnify, and hold SEA-BIRD ELECTRONICS, INC. harmless from all product liability claims arising from the use or servicing of this system.

Declaration of Conformity

Sea-Bird Electronics, Inc.
 13431 NE 20th Street Bellevue, WA 98005

DECLARATION OF CONFORMITY

Manufacturer's Name: Sea-Bird Electronics

Manufacturer's Address: 13431 NE 20th Street
 Bellevue, WA 98005, USA

Device Description: Various Data Acquisition Devices and Sensors

Model Numbers:

3S	3F	3plus	4C	4M	5M	5T
5P	7	8	9plus	11plusV2	14	16plusV2
16plusIM-V2	17plusV2	18	19plusV2	21	25plus	26plus
27	29	32	32C	32SC	33	35
35RT	36/PDIM	37-SI	37-SIP	37-IM	37-IMP	37-SM
37-SMP	38	39	39-IM	39plus	41	41CP
43	43F	44	45	48	49	50
52-MP	53	54	55	56	63	PN 90204
PN 90158.1	PN 90488	PN 90545	PN 90402	AFM	SIM	ICC
IMM/UIMM	Glider Payload CTD	NIMH Battery Charger & Battery Pack (PN 90504)				

Applicable EU Directives: Machinery Directive 2006/42/EC

EMC Directive 2004/108/EC

Low Voltage Directive (2006/95/EC)

Applicable Harmonized Standards:

EN 61326-1:2013 Class A Electrical Equipment for Measurement, Control and Laboratory Use, EMC Requirement - Part 1: General Requirements (EN 55011:2009 Group 1, Class A)

EN 61010-1:2010, Safety Requirements for Electrical Equipments for Measurement, Control, and Laboratory Use - Part 1: General Requirements

I, the undersigned, hereby declare that the equipment specified above conforms to the above European Union Directives and Standards.

Authorized Signature:	
Name:	Casey Moore
Title of Signatory:	President
Date:	June 6, 2014
Place:	Bellevue, WA

Table of Contents

Limited Liability Statement	2
Declaration of Conformity	3
Table of Contents	4
Section 1: Introduction	6
About this Manual	6
Unpacking SBE 36 / PDIM.....	7
Section 2: Description of SBE 36 / PDIM	8
System Description	8
Specifications.....	9
PDIM Dimensions and Connectors.....	10
SBE 36 Front Panel.....	11
SBE 36 Back Panel	11
Cables and Wiring	12
System Communications	16
NMEA and Surface PAR	17
Section 3: Setting Up System	19
Installing Software	19
Setting CTD Baud Rate and Operating Parameters	20
SBE 19, 19 <i>plus</i> (not 19 <i>plus</i> V2), 25 (not 25 <i>plus</i>), 49, or 50.....	20
SBE 19 <i>plus</i> V2 or 25 <i>plus</i>	22
Setting Up and Testing System.....	23
Changing Communication Settings between SBE 36 and Computer	26
Checking CTD Configuration (.xmlcon or .con) File in Seasave	27
Section 4: Mounting and Wiring System	28
Cable, Winch, and Deck Gear (not supplied by Sea-Bird)	28
Mounting SBE 36 and PDIM.....	28
Wiring System	29
Section 5: Operating System	31
Acquiring Real-Time Data with Seasave	31
Recovering CTD and PDIM	34
Uploading CTD Data from Memory.....	35
Processing Data Using SBE Data Processing	35
Editing Raw Data File.....	36
Section 6: Routine Maintenance	37
Corrosion Precautions	37
Connector Mating and Maintenance	37
Cleaning SBE 36 Deck Unit	38
Section 7: Troubleshooting	39
Problem 1: Unable to View Data in Seasave (Real-Time Data Acquisition program)	39
Problem 2: SBE 36 Completely Inoperable	39
Problem 3: CTD Does Not Respond.....	40
Problem 4: Yellow NMEA Transmit LED Not Flashing	40
Problem 5: Yellow <i>NMEA Transmit</i> LED Flashing, but Lat/Lon Data Not Displaying.....	40
Glossary	41
Safety and Electrical Symbols	42

Appendix I: NMEA Navigation Device Message and Data Formats 43
Message Formats43
Data Formats.....44

Appendix II: NMEA Message Simulation Program 45

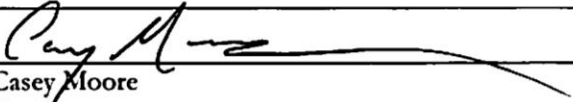
Appendix III: PDIM Electronics Disassembly/Reassembly 47

Appendix IV: Replacement Parts 48

Appendix V: Manual Revision History 49

Index..... 51

Section 1: Introduction

This section includes photos of a typical SBE 36 shipment.

About this Manual

This manual is to be used with the SBE 36 / PDIM CTD Power and Data System. It is organized to guide the user from installation through operation. We've included detailed specifications, setup and operation descriptions, and helpful notes throughout the manual.

Sea-Bird welcomes suggestions for new features and enhancements of our products and/or documentation. Please contact us with any comments or suggestions (seabird@seabird.com or 425-643-9866). Our business hours are Monday through Friday, 0800 to 1700 Pacific Standard Time (1600 to 0100 Universal Time) in winter and 0800 to 1700 Pacific Daylight Time (1500 to 0000 Universal Time) the rest of the year.

Unpacking SBE 36 / PDIM

Shown below is a typical SBE 36 / PDIM shipment. Inclusion of test cables, etc. is dependent on the order.



SBE 36 CTD Deck Unit



Rack mount kit
(screws not shown)



SBE 36 power cable



Computer to SBE 36 cable



PDIM



SBE 36 to PDIM
test cable



Sea Cable connector
(at SBE 36 end of cable)



NMEA Input
Interface test cable



NMEA Input connector



PDIM pigtail for
connection to sea cable



Software, and Electronic Copies of
Software Manuals and User Manual

Section 2: Description of SBE 36 / PDIM

This section describes the functions and features of the SBE 36 / PDIM Power / Data System, as well as system communications.

System Description

Notes:

- Except where noted, the term *CTD* refers to the SBE 19, *19plus*, *19plus V2*, and 25 CTD as well as the SBE 50 Pressure Sensor.
- Seasave also supports acquisition of data from a NMEA device connected directly to the computer (instead of the deck unit).
- Surface PAR channel was optional in earlier versions of the SBE 36.
- SBE 25: if the SBE 25 is integrated with more than 4 auxiliary voltage sensors, and the SBE 36 is appending both NMEA and Surface PAR data, you must set the SBE 25 real-time output rate to 4 scans/sec or less (see the SBE 25 manual for setup command details).
- SBE 49: Seasave 7.23.2 and later supports acquisition of Surface PAR data.
- SBE *25plus*: If the SBE 36 is appending both NMEA and Surface PAR, you must slow down the real-time output rate by setting **SetHistoricRate=0** (see the *25plus* manual for command details).
- SBE 50: Seasave does not support this system; real-time data can be viewed in Seaterm (terminal program). Surface PAR data (if applicable) is output as raw data.

The SBE 36 Deck Unit provides continuous power and real-time data acquisition and control for an SBE 19, *19plus*, *19plus V2*, 25, *25plus*, or 49 CTD, or SBE 50 Pressure Sensor, interfacing with a Power / Data Interface Module (PDIM). The SBE 36 remains at the surface, while the PDIM (depth to 6800 m) is installed on or near the CTD. The system allows for two-way communication for the CTD over a single-conductor sea cable.

The rack-mountable SBE 36 supplies DC power for the underwater unit(s), decodes the serial data, and passes the data to a computer. The SBE 36 back-panel switch permits operation from 120 VAC or 240 VAC 50/60 Hz input power. The SBE 36 transmits data to the computer at 9600 or 19200 baud, 7 or 8 data bits, and no or even parity.

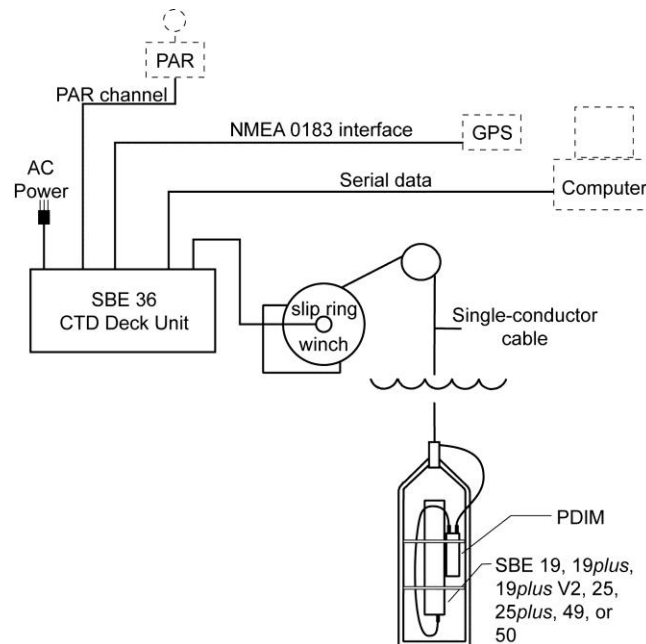

Notes:

For NMEA depth data (DBT or DPT):

- Depth data can be decoded and merged with CTD data only if NMEA position data (GGA, GLL, RMA, RMC, or TRF) is also available.
- Seasave (real-time data acquisition software) and SBE Data Processing (post-processing software) are compatible with NMEA depth data in the data stream.

The SBE 36 can merge position data with CTD data. The SBE 36 decodes messages that are output from navigation devices supporting NMEA 0183 protocol, in one or more of the following formats:

- GGA - Global Positioning System Fix Data
- GLL - Geographic Position: Latitude/Longitude
- RMA - Recommended Minimum Specific Loran-C Data
- RMC - Recommended Minimum Specific GPS/TRANSIT Data
- TRF - TRANSIT Fix Data
- DBT - Depth Below Transducer
- DPT - Depth

Decoded NMEA data is appended to the CTD data stream in the SBE 36, and are passed to the computer for storage and/or display with the CTD data.

The SBE 36 includes an A/D converter for a Surface PAR light sensor. The SBE 36 supplies 12 volts to power the sensor, and appends the data to the CTD data stream.

Notes:

- Help files provide detailed information on the software.
- NMEATest, a NMEA navigation device simulation program, is part of the SBE Data Processing installation.
- Separate software manuals on CD-ROM contain detailed information on Seasave and SBE Data processing.
- Sea-Bird supplies the current version of our software when you purchase an instrument. As software revisions occur, we post the revised software on our website. See our website for the latest software version number, a description of the software changes, and instructions for downloading the software.

The SBE 36 is supplied with a powerful Windows software package, Seasoft V2, which includes:

- **Seaterm** and **SeatermV2** – terminal programs for easy setup.
- **Seasave V7** – program for acquiring, converting, and displaying real-time or archived raw data.
- **SBE Data Processing** – program for calculation and plotting of conductivity, temperature, pressure, auxiliary sensor data, and derived variables such as salinity and sound velocity.

Specifications

The SBE 36 supplies a constant 250 VDC power to the sea cable. The PDIM receives this voltage (minus the sea cable IR drop) and regulates it to a constant 64 VDC. This 64 VDC is input to a high-efficiency DC/DC converter, which outputs + 15 VDC. The +15 VDC is the supply voltage to the CTD. Approximately 1 amp, *in addition to CTD power*, is available at the CTD for support of auxiliary sensors.

Power Requirements	120VAC at 60Hz and 1.75A or 240VAC at 50Hz and 1A switchable
Sea Cable Compatibility	Single or multi-core armored cable up to 10,000 meters (32,800 feet) long with inner core resistance of up to 350 ohms
SBE 36 CTD Deck Unit Dimensions and Weight	9 cm tall x 37.5 cm deep x 44.4 cm wide cabinet; 46.4 cm edge-to-edge for mounting brackets (distance centerline to centerline of mounting holes 46.4 cm). <i>Feet</i> add 1.3 cm to height. 9.9 kg (22.6 lbs)
SBE 36 CTD Deck Unit Installation Environment	SBE 36 operates properly under following conditions: <ul style="list-style-type: none"> • Indoor use • Altitude up to 2000 meters • Temperature from 5 °C to 40 °C • Maximum relative humidity 80%, non-condensing • Mains supply voltage $\pm 10\%$
PDIM Depth Rating	6800 m (22,300 ft)
PDIM Weight	3.6 kg (8 lbs) in air, 1.6 kg (3.6 lbs) in water. See <i>PDIM Dimensions and Connectors</i> below.

PDIM Dimensions and Connectors

Order PDIM with desired type of bulkhead connector:

- PN 90227 - PDIM with XSG connectors
- PN 90473 - PDIM with MCBH wet-pluggable connectors

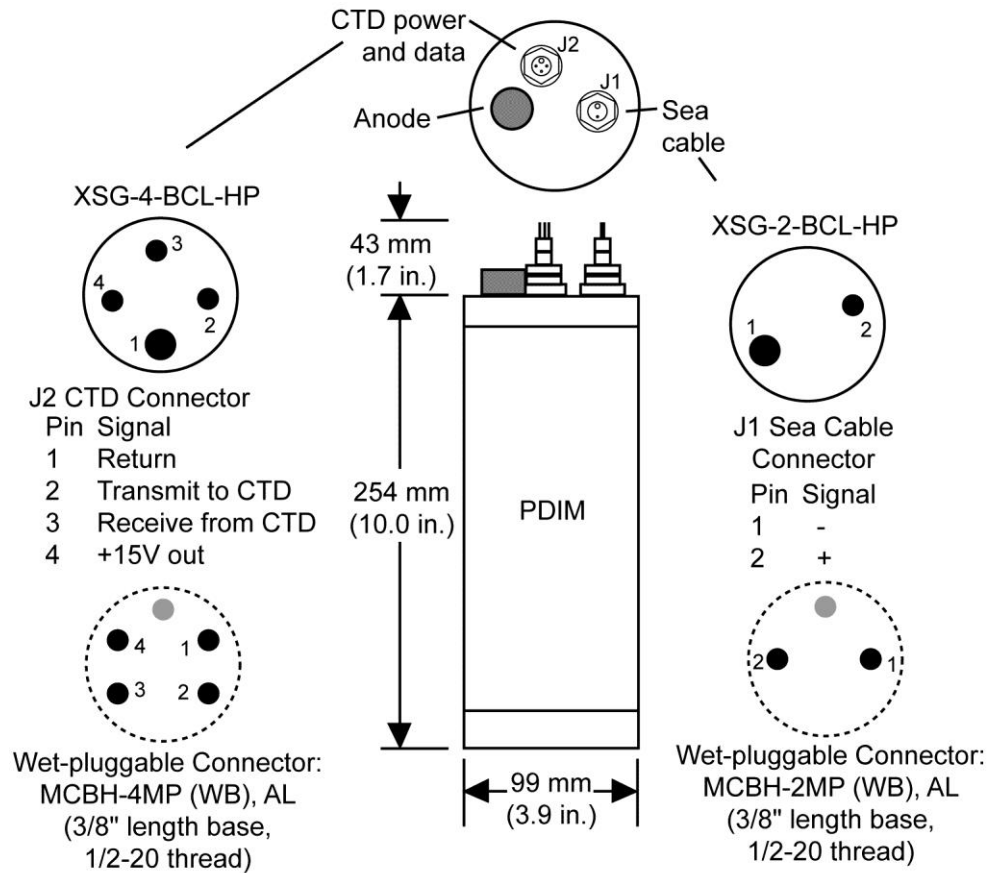

SBE 36 Front Panel

Looking at the SBE 36 front panel:

- *Power* button - turns power to the SBE 36 on/off
- *LEDs* - indicate if the SBE 36 is communicating with other parts of the system:
 - Yellow *NMEA Transmit* LED - flashes when a carriage return character (decimal 13) is received from the NMEA navigation device
 - Yellow *CTD Transmit* LED - flashes when a carriage return character (decimal 13) is received from the CTD through the PDIM
 - Green *CTD Receive* LED - flashes when a message is transmitted to the CTD through the PDIM

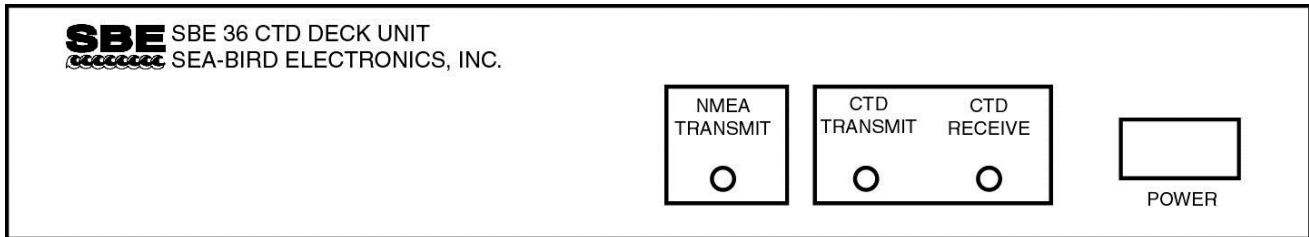

SBE 36 Back Panel

Looking at the connections to the SBE 36 back panel:

Note:

The SBE 36 uses the same back panel as the SBE 33 (which has many of the same functions as the SBE 36 but also controls a water sampler). The *Carousel Data* connector is not used with the SBE 36.

- *Serial Data* - to the computer.
- *NMEA Input* - to a NMEA navigation device.
- *PAR Input* - to a Surface PAR sensor.
- *Sea Cable* - to the PDIM.
Fuse – 3AG, 300VDC, Fast Acting, 0.5A. Replace with Littelfuse Corp. 312.500 only.
- *AC Input* - 120 VAC or 240 VAC 50/60 Hz (selectable).
Fuse 5x20mm, 250VAC Slow-Blow, 2 amp (for 120 V) or 1 amp (for 240 V)

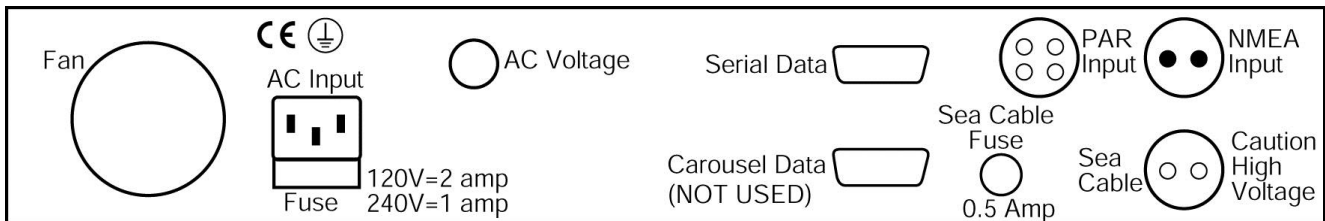

Cables and Wiring

DB9 to DB9 cable –
SBE 36 *Serial Data*
connector to computer

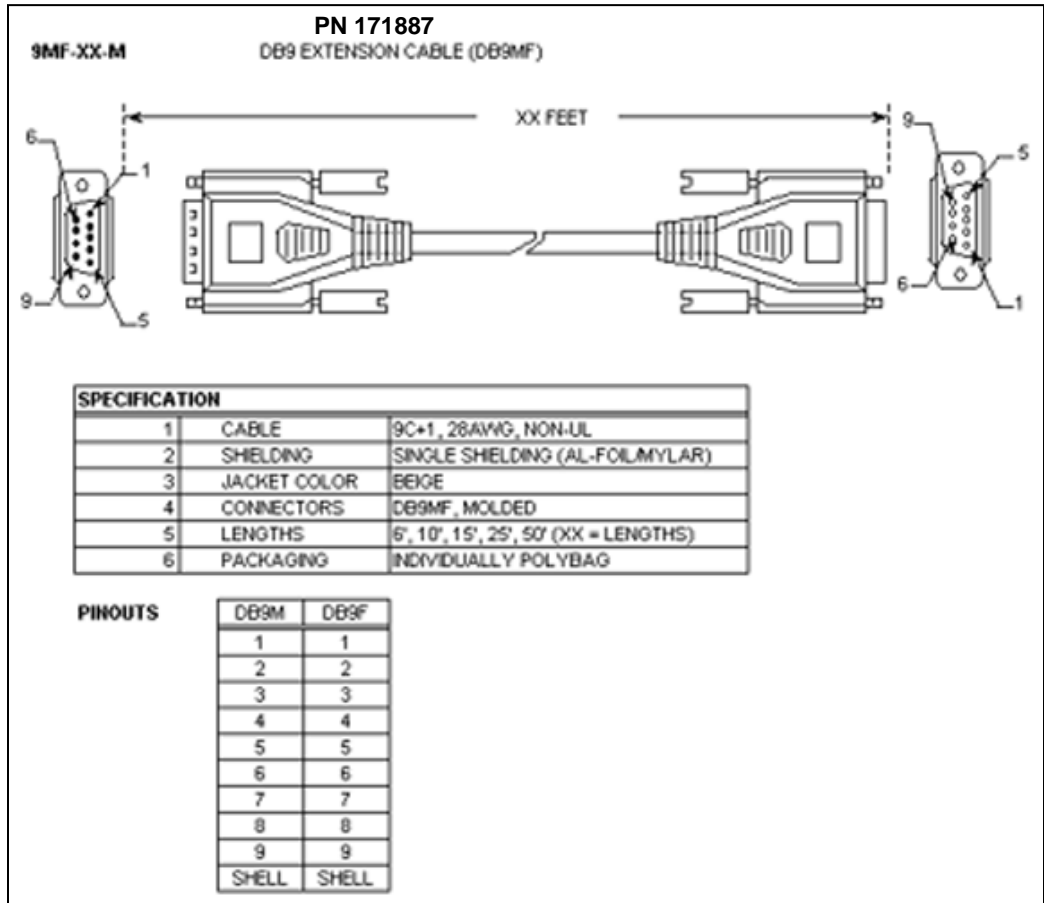

2-pin to 2-pin Test
Cable - SBE 36
Sea Cable to PDIM

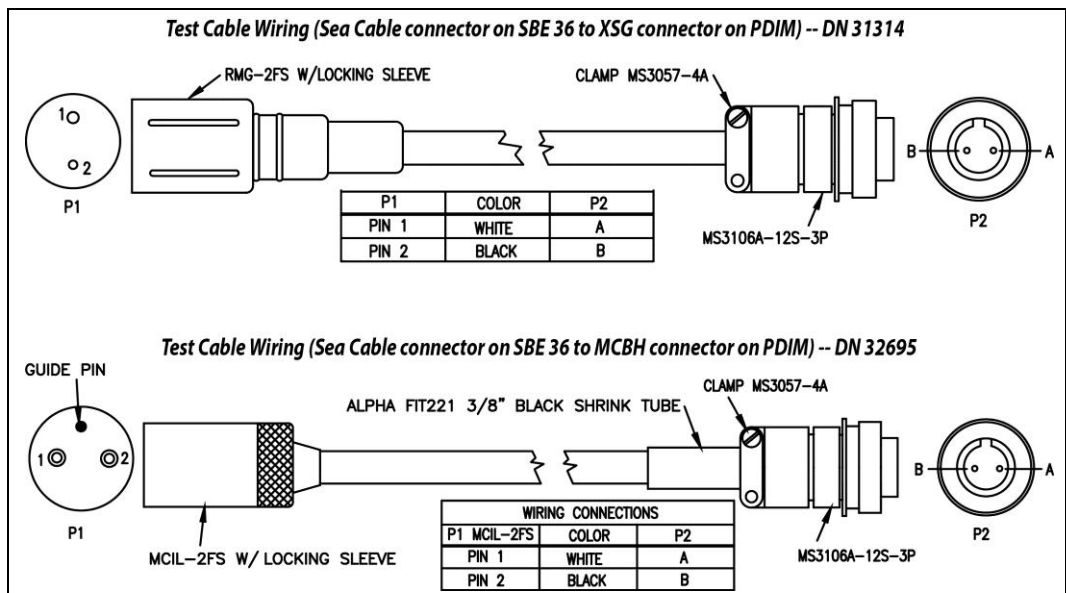

**2-pin SBE 36
Sea Cable to
slip ring**

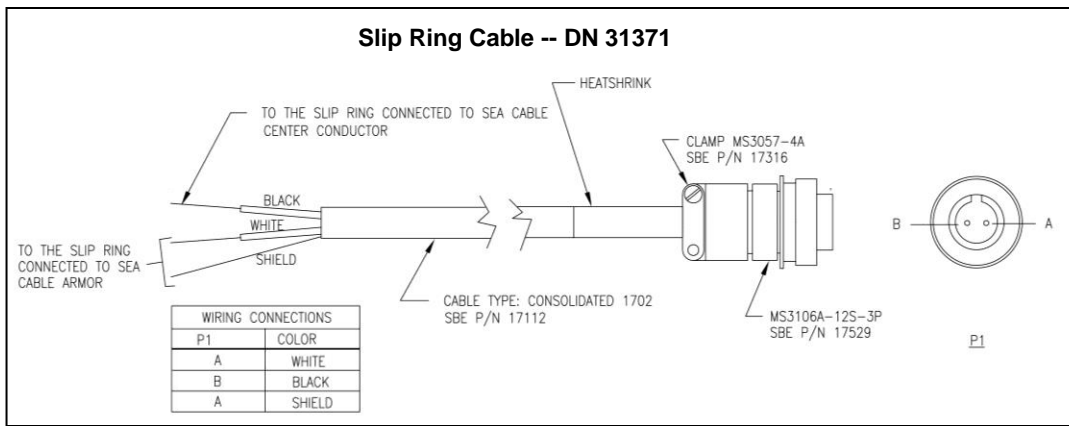

**4-pin to 4-pin cable
- PDIM to CTD**

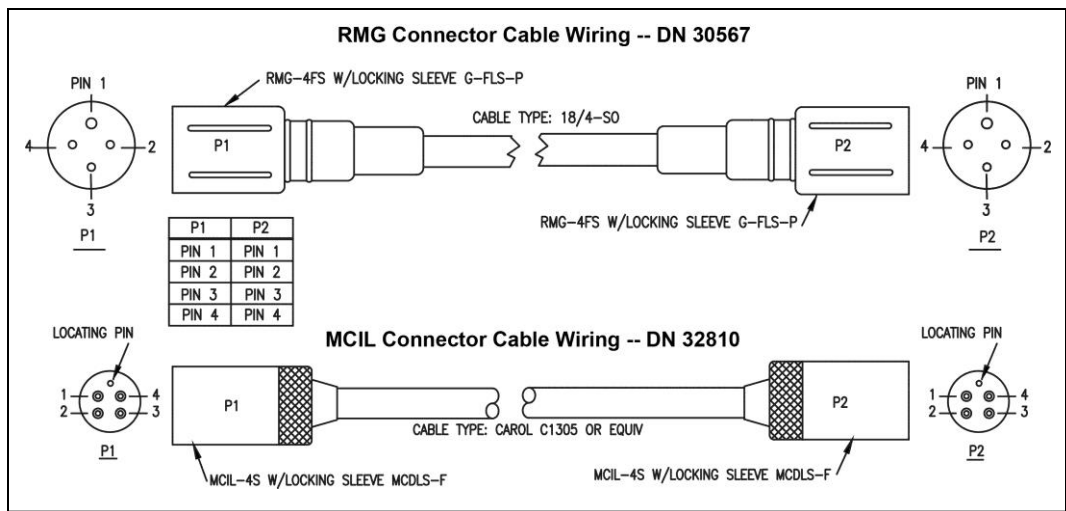

**2-pin to DB9 Test
cable - SBE 36
NMEA Input to
computer**

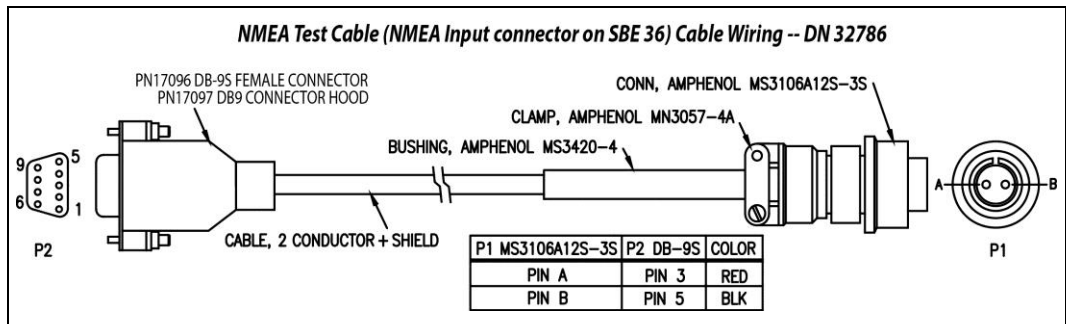

Notes:

- The Switchcraft connector on the Biospherical Surface PAR sensor is the current connector type. Biospherical sold the Surface PAR sensor with other connector types in the past. See the appropriate drawing for pinout details.
- SBE 36 can also be used with a Satlantic (Sea-Bird Scientific) Surface PAR sensor. Wiring diagram for that cable is not currently available.

4-pin SBE 36
PAR Input to
Biospherical
Surface PAR
sensor

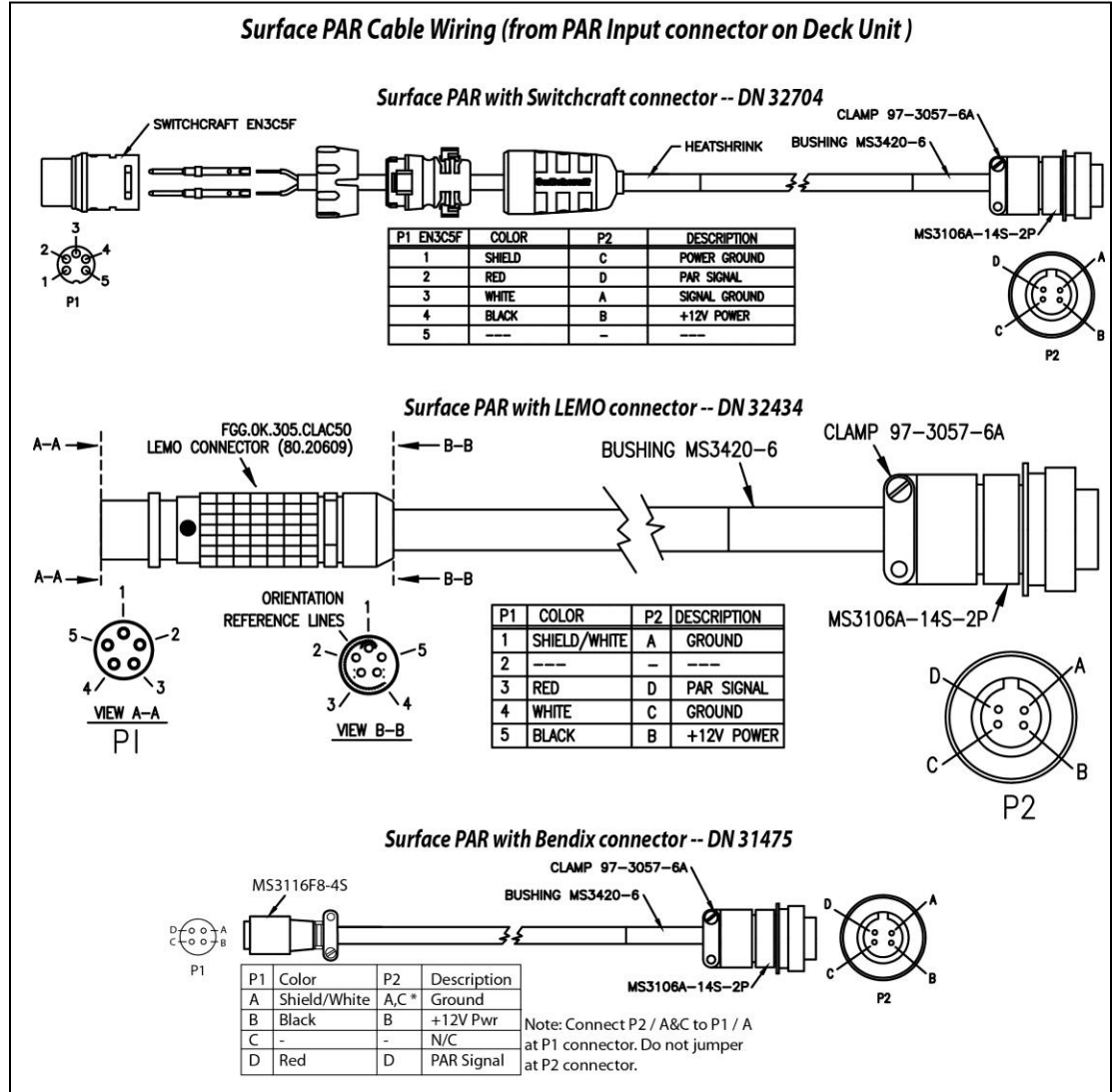

**PDIM
Internal
Wiring**

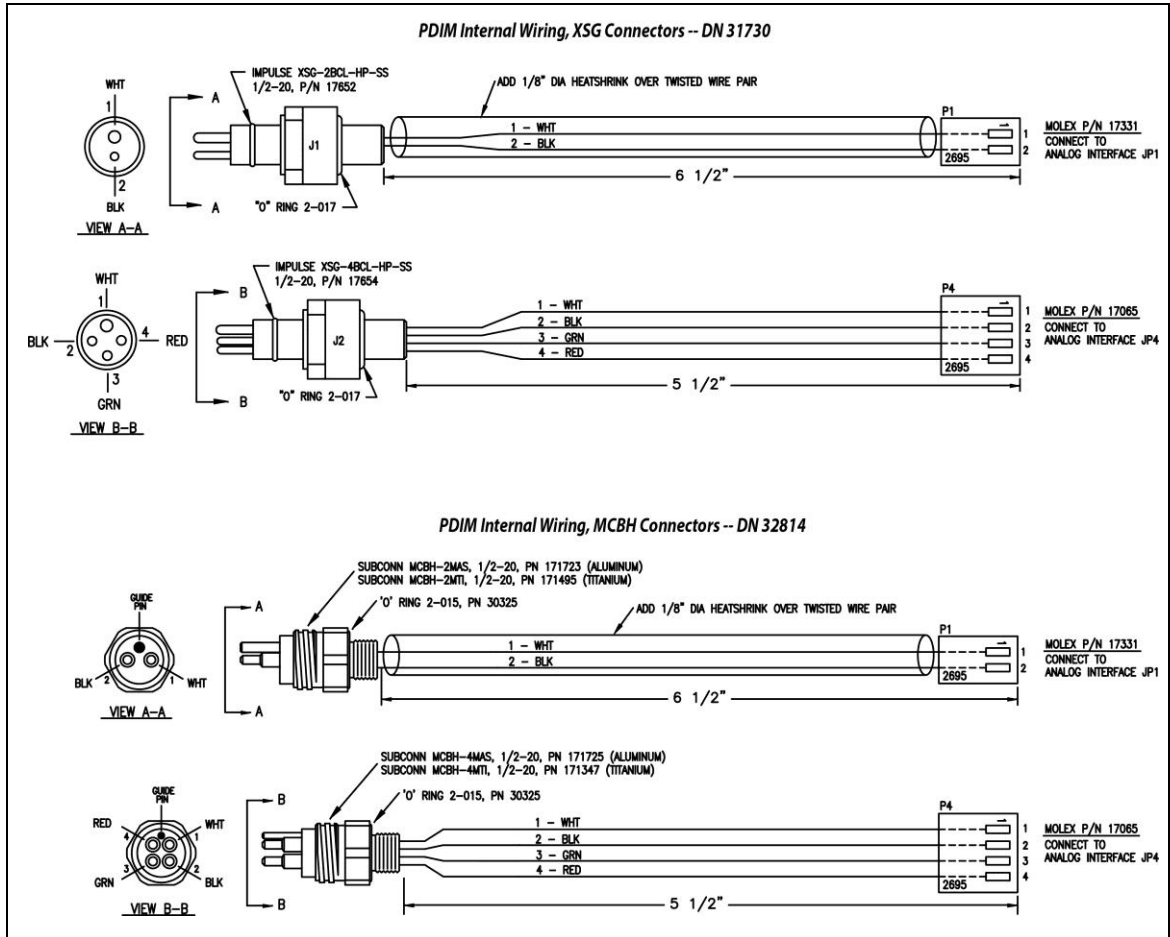

System Communications

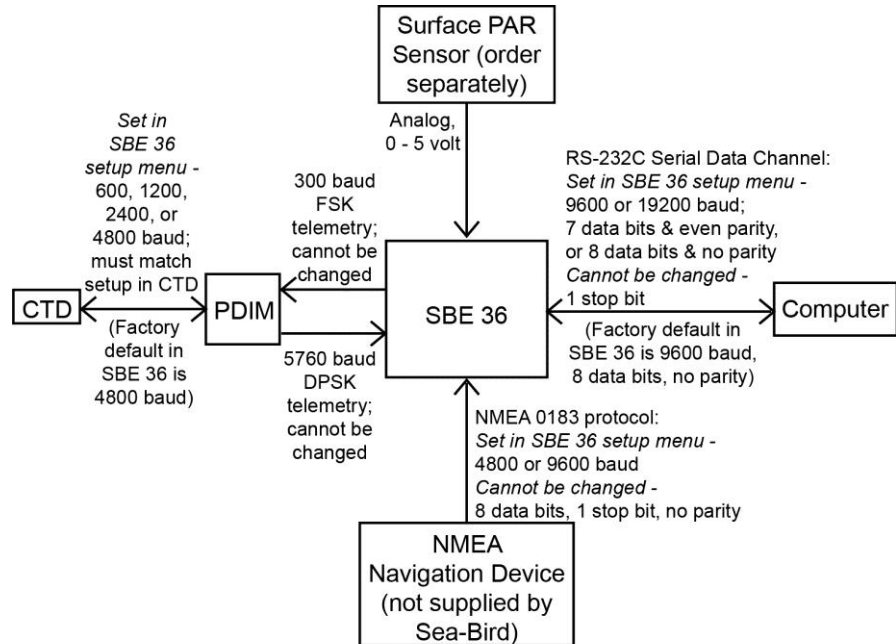

Notes:

- Abbreviations: DPSK = differential phase shift keyed, FSK = frequency shift keyed.
- Surface PAR Sensor input: Surface PAR channel was optional in earlier versions of the SBE 36.
- Data bits and parity between SBE 36 and computer must match data bits and parity of CTD (8 data bits and no parity for SBE 19*plus*, 19*plus* V2, 25*plus*, 49, or 50; 7 data bits and even parity for SBE 19 or 25)
- Seasave also supports acquisition of data from a NMEA device connected directly to the computer (instead of the deck unit).
- SBE 25: if the SBE 25 is integrated with more than 4 auxiliary voltage sensors, and the SBE 36 is appending both NMEA and Surface PAR data, you must set the SBE 25 real-time data output rate to 4 scans/sec or less (see the SBE 25 manual for command details).
- SBE 25*plus*: If the SBE 36 is appending both NMEA and Surface PAR, you must slow down the real-time output rate by setting **SetHistoricRate=0** (see the 25*plus* manual for command details).
- SBE 49: Seasave 7.23.2 and later supports acquisition of Surface PAR data.
- SBE 50: Seasave does not support this system; real-time data can be viewed in Seaterm (terminal program). Surface PAR data (if applicable) is output as raw data.

NMEA and Surface PAR

Notes:

- If you are not sure which NMEA messages your navigation device is sending, see *Section 7: Troubleshooting* for information on viewing the raw NMEA message using the SBE 36's diagnostic mode.
- SBE 25: if the SBE 25 is integrated with more than 4 auxiliary voltage sensors, and the SBE 36 is appending both NMEA and Surface PAR, you must set the SBE 25 real-time output rate to 4 scans/sec or less (see SBE 25 manual for command details).
- SBE 25*plus*: If the SBE 36 is appending both NMEA and Surface PAR, you must slow down the real-time output rate by setting **SetHistoricRate=0** (see the 25*plus* manual for command details).
- SBE 49: Seasave (real-time data acquisition software) 7.23.2 and later supports acquisition of Biospherical Surface PAR data.
- SBE 50: Seasave does not support this system; real-time data can be viewed in Seaterm (terminal program). Surface PAR data (if applicable) is output as raw data.
- Seasave (real-time data acquisition software) 7.26.7 and later supports acquisition of Satlantic Surface PAR data.

The SBE 36 includes a NMEA 0183 interface that permits NMEA data to be merged with the CTD data. The SBE 36 is designed to decode messages that are output from devices supporting NMEA 0183 protocol. Decoded NMEA data can be appended to the end of the CTD data stream in the SBE 36 and passed to the computer for storage and/or display with the CTD data (see *Appendix I: NMEA Device Message and Data Formats*). The Yellow *NMEA Transmit* LED on the SBE 36 front panel flashes each time a NMEA message is received (should be same rate at which your NMEA device is transmitting). The SBE 36 appends the same NMEA message multiple times, until a new message is decoded.

- *Example:* A NMEA device outputs its message once every 5 seconds. The Yellow *NMEA Transmit* LED flashes every 5 seconds, and the same message is appended to each scan of CTD data within that 5 seconds.

If NMEA position data is being added to the data stream, the SBE 36 also allows for the addition of NMEA depth (for example, from a NMEA echo sounder) to the data stream.

The SBE 36 can also acquire the 0 to 5 volt output of a Surface PAR sensor, append it to the CTD data stream, and pass it to the computer for storage and/or display with the CTD data. Seasave and SBE Data Processing support the acquisition and display of data from the following sensors:

- Satlantic (Sea-Bird Scientific) Surface PAR sensor (logarithmic or linear)
- Biospherical (QSR-240, QCR-240, QSR-2200, or QCR-2200) Surface PAR sensor

Notes:

- In Seaterm, use the @ character to access and exit the setup menu.
- The SBE 36 must be in Mode 1 if trying to send commands to the CTD through the SBE 36 and PDIM.
- To enter diagnostic modes (10 and/or 11), first put the SBE 36 in Mode 3. Then, enter a 10 or 11 at the mode selection prompt.
- To exit diagnostic modes (10 and/or 11), turn off power to the SBE 36.

The SBE 36 has three operating modes and two diagnostic modes, as well as two NMEA depth options and two Surface PAR options, and selections for setting and displaying communication parameters and start-up behavior. Mode is selected in the setup menu while communicating with the SBE 36 with Seaterm (see *Setting Up and Testing System* in Section 3: *Setting Up System*).

Type	Mode	Description
Operating Modes	1: Echo only	Characters to and from CTD pass through SBE 36. No NMEA or Surface PAR data is sent. Useful for setting up CTD without needing to disconnect CTD from system and connect it directly to computer.
	2: Add Lat/Lon to hex data	7 bytes of hex latitude/longitude data is added to each line of hex data from CTD. Used when position data is required with CTD data. If Options 4 and/or 6 are selected, NMEA depth data and/or Surface PAR are also appended.
	3: Transmit Lat/Lon only	Data from CTD is not transmitted. Hex latitude/longitude data is converted to ASCII text whenever a new position is received from NMEA device. Format is: LAT 47 37.51 N LON 122 09.41 W If NMEA message RMC is decoded, date and time display on next line. Format is: DDMMYY HHMMSS
Options	4. Add NMEA Depth to real-time Hex/Lat/Lon data	3 bytes of depth data (for example, from a NMEA echo sounder) is added to each line of hex data from CTD, after lat/lon data.
	5. Do not add NMEA Depth to real-time Hex/Lat/Lon data	NMEA depth data is not added.
	6. Add PAR to real-time HEX data	3 bytes of Surface PAR data is added to each line of hex data from CTD, before lat/lon/depth data.
	7. Do not add PAR to real-time HEX data	Surface PAR data is not added.
Communication Settings and Start Modes	8. Change communication settings and start mode	Set/reset baud rates, data bits, and parity, NMEA baud rate, and start mode (whether SBE 36 starts in Operating Mode 1 or 2 when power applied).
	9. Display communication settings and start mode	Display settings set up in Mode 8.
Diagnostic	10. Enable diagnostic level 1 (transmit raw NMEA messages)	All NMEA messages received are echoed to computer in raw form. Used to determine which NMEA messages are being received by SBE 36.
	11. Enable diagnostic level 2 (transmit decoded NMEA messages)	All NMEA messages received are decoded by SBE 36 and displayed on computer. If you select mode 10 and then select mode 11, SBE 36 transmits raw data followed by decoded data.

Section 3: Setting Up System

This section covers:

- Installing Sea-Bird software
- Setting the baud rate in the CTD
- Setting up and testing the SBE 36
- Changing communication settings between the SBE 36 and computer
- Setting up the CTD configuration (.xmlcon or .con) file

Installing Software

Seasoft V2 was designed to work with a PC running Windows XP service pack 2 or later, Windows Vista, or Windows 7 (32-bit or 64-bit).

Notes:

- Help files provide detailed information on the software.
- NMEATest, a NMEA navigation device simulation program, is part of the SBE Data Processing installation.
- Separate software manuals on CD-ROM contain detailed information on Seasave and SBE Data Processing.
- Sea-Bird supplies the current version of our software when you purchase an instrument. As software revisions occur, we post the revised software on our website. See our website for the latest software version number, a description of the software changes, and instructions for downloading the software.

If not already installed, install Sea-Bird software programs on your computer using the supplied software CD.

1. Insert the CD in your CD drive.
2. Install software: Double click on **SeasoftV2.exe**. Follow the dialog box directions to install the software. The installation program allows you to install the desired components. Install all the components, or just install Seaterm (terminal program), SeatermV2 (for use when directly communicating with an SBE 19*plus* V2 or 25*plus*), Seasave V7 (real-time data acquisition), and SBE Data Processing (data processing).

The default location for the software is c:\Program Files\Sea-Bird. Within that folder is a sub-directory for each program.

Setting CTD Baud Rate and Operating Parameters

Note:

The SBE 36 is factory-programmed to command the PDIM to communicate with the CTD at 4800 baud. The setting in the SBE 36 must match the baud rate programmed in the CTD. **For the most efficient operation, keep the baud at 4800 baud if it is feasible for the CTD.**

PDIM communication with the CTD is at 600, 1200, 2400, or 4800 baud. **For the most efficient operation, set the CTD baud rate to 4800 baud.**

SBE CTD	CTD Baud Rates Compatible with SBE 36/PDIM	CTD Firmware Version
19	600 or 1200	3.0d and later, programmable
	600, 1200, or 4800	3.1d and later (but not 4.0 series), programmable
	600, 1200, 2400, or 4800	Prior to 3.0d, contact Sea-Bird for instructions on changing baud rate if necessary
19plus or 19plus V2	1200, 2400, or 4800	All versions, programmable
25	600, 1200, or 4800	3.0K and later, programmable
	600, 1200, 2400, or 4800	Prior to 3.0K, contact Sea-Bird for instructions on changing baud rate if necessary
25plus	600, 1200, 2400, or 4800	All versions, programmable
49	1200, 2400, or 4800	All versions, programmable
50	1200, 2400, or 4800	All versions, programmable

The baud rate for PDIM communication with the CTD must be set in both the CTD and in the SBE 36.

Note:

SBE 19plus V2 and 25plus use a different terminal program; see *SBE 19plusV2 or 25plus* below.

SBE 19, 19plus (not 19plus V2), 25 (not 25plus), 49, or 50

Set (if programmable) and/or verify the CTD baud rate, and establish CTD operating parameters:

1. **Connect the CTD directly to the computer** (not through the PDIM and SBE 36), using the data I/O cable supplied with the CTD.
2. Double click on **Seaterm.exe**. If this is the first time the program is used, the setup dialog box may appear:



Select the CTD and the computer COM port for communication with the CTD. Click OK.

3. The main screen looks like this (example shown is for SBE 19plus):

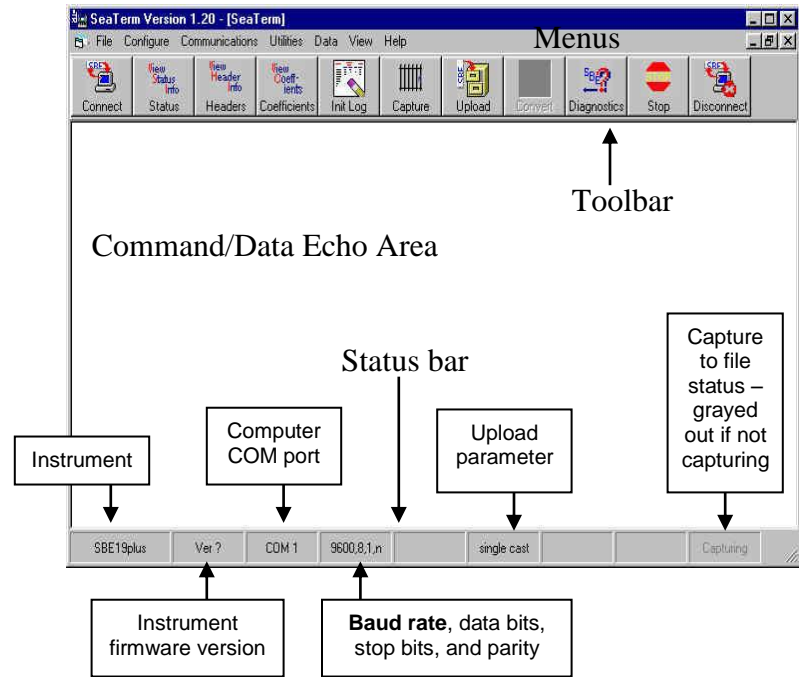

4. In the Configure menu, select the appropriate CTD.
5. In the dialog box, click the COM settings tab. Select the firmware version, COM port, baud rate, data bits, and parity (see the CTD configuration sheet). Click OK to save the settings and exit the dialog box.
6. In the Communications menu, select *Options / Cycle baud when connecting*.
7. Click Connect on the Toolbar. Seaterm tries to connect at the baud set in Step 5. If it cannot, it cycles through all other possible bauds to try to connect. An S> prompt shows that communication has been established.
8. Look at the connection baud rate in the Status bar. If this is not a baud that can be used with the PDIM (600, 1200, 2400, or 4800), change the baud in the CTD. The command to change the baud is given below for CTDs with programmable baud (contact Sea-Bird for instructions on older CTDs):
 - SBE 19 - Send **SBn**, where n = 1 (600 baud), 2 (1200 baud), or 6 (4800 baud - for firmware version 3.1d and above in the 3.0 series; not applicable to the 4.0 series).
 - SBE 19plus, 49, or 50 - Send **Baud=x**, where x = 1200, 2400, or 4800.
 - SBE 25 - Send **SRx**, where x= 1 (600 baud), 2 (1200 baud), or 4 (4800).
9. Click Connect on the Toolbar again, and verify that the Status bar shows the new baud rate. Record the baud rate - you must also set the CTD baud rate in the SBE 36 (see *Setting Up and Testing System*).
10. Establish other CTD setup and logging parameters (see CTD manual). Note the following requirements for use with the SBE 36/PDIM:
 - SBE 19plus – Set **OutputFormat=0** (raw hex).
 - SBE 49 – Set **OutputFormat=0** (raw hex). For typical use, set **AutoRun=Y** so the SBE 49 starts sampling automatically when power is applied.
 - SBE 50 – Set **AutoRun=Y** so the SBE 50 starts sampling automatically when power is applied.
11. Send **QS** to put the CTD in quiescent (sleep) state (not applicable to SBE 49 or 50).

Notes:

- The SBE 36's factory-default setup commands the PDIM to communicate with the CTD at 4800 baud. The setting in the SBE 36 must match the baud rate programmed in the CTD. **For the most efficient operation, keep the baud at 4800 baud if it is feasible for the CTD.** See *Setting Up and Testing System*.
- Once all baud rates are set, you can also communicate with and change the setup of the CTD **through** the SBE 36 and PDIM using Seaterm. See *Setting Up and Testing System*.

Note:

The other CTDs that are compatible with the SBE 36 use a different terminal program; see *SBE 19, 19plus, 25, 49, or 50* above.

SBE 19plus V2 or 25plus

The SBE 19plus V2 and 25plus use a different terminal program than the older CTDs. Set and/or verify the CTD baud rate, and establish CTD operating parameters:

1. **Connect the CTD directly to the computer** (not through the PDIM and SBE 36), using the data I/O cable supplied with the CTD.
2. Double click on **SeatermV2.exe**; SeatermV2 opens.

Notes:

- The SBE 36's factory-default setup commands the PDIM to communicate with the CTD at 4800 baud. The setting in the SBE 36 must match the baud rate programmed in the CTD. **For the most efficient operation, keep the baud at 4800 baud if it is feasible for the CTD.** See *Setting Up and Testing System*.
- Once all baud rates are set, you can also communicate with and change the setup of the CTD **through** the SBE 36 and PDIM using Seaterm. See *Setting Up and Testing System*.

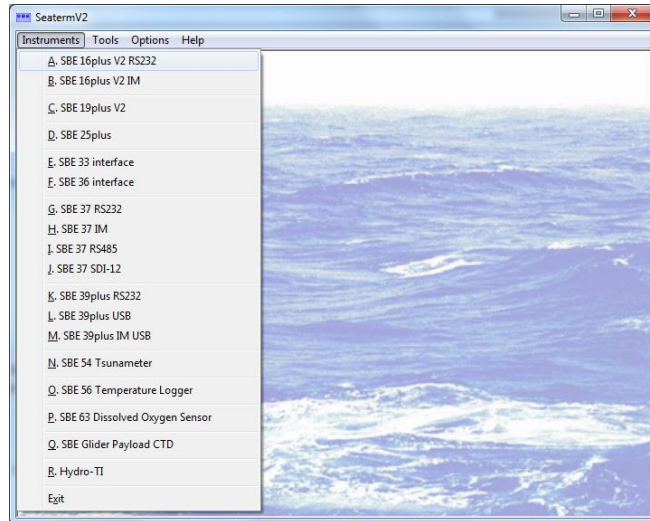

3. Select your CTD in the Instruments menu; Seaterm232 opens.
4. Follow the instructions in the software Help for connecting to the CTD.
5. Look at the connection baud rate in the title bar of the Command/Data Echo Area. If this is not a baud that can be used with the 36/PDIM (≤ 4800):
 - A. Change the baud in the CTD:
 - SBE 19plus V2: **BaudRate=x**, where $x = 1200, 2400, \text{ or } 4800$.
 - SBE 25plus: **SetBaudConsole=x**, where $x = 600, 1200, 2400, \text{ or } 4800$.
 - B. Reconnect to the CTD at the new baud rate (see the software Help for details); verify that the title bar of the Command/Data Echo area shows the new baud rate.
 - C. Record the baud rate; you must also set the CTD baud rate in the SBE 36 (see *Setting Up and Testing System*).
6. Establish other CTD setup and logging parameters (see 19plus V2 manual). Note the following requirement for use with the SBE 36/PDIM:
 - SBE 19plus V2: Set **OutputFormat=0**.
 - SBE 25plus: Set **SetOutputFormat=0**.
7. Send **QS** to put the 19plus V2 in quiescent (sleep) state.

Setting Up and Testing System

Notes:

- You can also launch Seaterm from SeatermV2; you may find this useful when using the SBE 36 with a CTD that uses SeatermV2 (e.g., 19plus V2 or 25plus). In SeatermV2's Instruments menu, select SBE 36 interface; Seaterm opens. The remaining instructions (Step 2 and higher) are unchanged.
- The SBE 36 must be connected to the PDIM to setup and test the system. If it is not connected, noise on the open *Sea Cable* connector will interfere with communication with the SBE 36.

1. Double click on seaterm.exe; Seaterm opens.
2. In Seaterm's Configure menu, select the SBE 36.
 - A. In the Configuration Options dialog box, click on the COM Settings tab and set the COM Settings:
 - Comm Port - for connection to SBE 36 (1 through 10 as applicable)
 - Baud rate between SBE 36 and computer - 9600 or 19200 (factory set to 9600)
 - Data bits and parity - SBE 19plus, 19plus V2, 25plus, 49, or 50 - 8 data bits, no parity. SBE 19 or 25 - 7 data bits, even parity.
 Click *OK* to save the settings and exit the dialog box.
3. Turn on power to the SBE 36. The SBE 36 status message displays in Seaterm:

```
SBE 33/36 Deck Unit V3.0 setup:
PC baud rate = 9600
CTD baud rate = 4800
8 data bits, no parity
NMEA baud rate = 4800
NMEA messages decoded = GGA, GLL, RMA, RMC, TRF, DBT, DPT
Surface PAR disabled
NMEA depth disabled
start mode = echo characters to and from the instrument
press @ to change the 33/36 Deck Unit setup
```

Notes:

- **If the communication settings you set in Seaterm's Configure menu do not match the communication settings in the SBE 36 for communication between the SBE 36 and computer (factory default 9600 baud, 8 data bits, no parity), the display will show *garbage* characters.** If this happens, go to *Changing Communication Settings between SBE 36 and Computer* below before proceeding.
- If in the setup menu and no user input is received within 60 seconds, the SBE 36 times out and exits the setup menu. Re-enter the setup menu by typing @.
- If NMEA depth is enabled (using a NMEA depth device as well as a NMEA position device) and/or Surface PAR is enabled, the description for Start mode changes to include NMEA Depth and PAR, as applicable:
start mode = Add Lat/Lon/**Depth/PAR** to the real-time HEX data

Looking at selected lines:

Text	Description
SBE 33/36	Both the SBE 33 and SBE 36 use the same setup procedure.
PC baud rate	Baud for communication between computer and SBE 36 - 9600 or 19200 (factory default 9600).
CTD baud rate	Baud for communication between CTD and PDIM - 600, 1200, 2400, or 4800 (factory default 4800). Upon power-up, the SBE 36 reads this setting and automatically sends a command to the PDIM to set its baud rate. For the most efficient operation, keep the baud rate at 4800 baud if it is feasible for the CTD. Baud rate must be set in both the SBE 36 and in the CTD.
8 data bits, no parity	Data bits and parity for communication between computer and SBE 36 - set to 8 data bits and no parity for SBE 19plus, 19plus V2, 25plus, 49, or 50 (factory default), or 7 data bits and even parity for SBE 19 or 25. Must match data bits and parity of CTD.
NMEA baud rate	Baud for communication between SBE 36 and NMEA device, factory set in SBE 36 to 4800 (must match NMEA device).
NMEA messages decoded	Output from NMEA device must match one of these messages.
Start mode	Defines default behavior on power-up. <i>Echo characters to and from the instrument</i> (factory default) puts SBE 36 in Mode 1 on power-up, allowing system to communicate with CTD, so CTD can be set up through SBE 36. <i>Add Lat/Lon to the real-time HEX data</i> puts SBE 36 in Mode 2 on power-up, allowing system to start acquiring Hex and NMEA position data (and NMEA depth and/or Surface PAR, as applicable).

4. Type @ to access the setup menu. The display looks like this:

```
SBE 33/36 Deck Unit set up menu:
Modes:
1. Echo characters to and from the instrument
2. Add Lat/Lon to the real-time HEX data from the instrument
3. Transmit Lat/Lon only
Options:
4. Add NMEA Depth to the real-time HEX/Lat/Lon data
5. Do not add NMEA Depth to the real-time HEX/Lat/Lon data
6. Add PAR to the real-time HEX data
7. Do not add PAR to the real-time HEX data
Communications:
8. Change communication settings and start mode
9. Display communication settings and start mode
Diagnostics:
10. enable diagnostic level 1
11. enable diagnostic level 2
```

Note:
If NMEA depth is enabled (using a NMEA depth device as well as a NMEA position device) and/or Surface PAR is enabled, the description for mode 2 changes to include NMEA Depth and/or PAR, as applicable:
2. Add Lat/Lon/**Depth**/**PAR** to the real-time HEX data from the instrument

the current mode = 1. Echo characters to and from the instrument

enter 1, 2, 3, 4, 5, 6, 7, 8, 9, 10, or 11 followed by Enter, or press @ to exit the set up menu

selection =

5. To view the current communication and start mode settings, type 9 and press the Enter key. The display looks like this:

```
PC baud rate = 9600
CTD baud rate = 4800
8 data bits, no parity
NMEA baud rate = 4800
NMEA messages decoded = GGA, GLL, RMA, RMC, TRF, DBT, DPT
Surface PAR disabled
NMEA depth disabled
start mode = Echo characters to and from the instrument
```

Note:
The communication and start mode settings were also shown in the status message that appeared when you turned on power to the SBE 36; see Step 3 above.

If the *CTD baud rate* does not match the baud rate set in your CTD, the computer will not be able to communicate with the CTD through the SBE 36. Step 6 provides instructions for changing the CTD baud rate in the SBE 36 to match your CTD.

6. To change the current communication settings and/or start mode settings, type 8 and press the Enter key. The display looks like this:

```
PC baud rate = X, new value = (type desired value, press Enter)
CTD baud rate = X, new value = (type desired value, press Enter)
parity = X, new value = even parity or no parity [e/n] (type e or n, press Enter)
NMEA baud rate = X, new value = (type desired value, press Enter)
Start mode = X, new value = echo or add Lat/Lon [e/a] (type e or a, press Enter)
```

The display then shows your new selections. Type @ to return to the setup menu.

7. Type 1 and press the Enter key to put the SBE 36 in **mode 1** (*echo characters to and from the instrument*), **which is the mode required for communicating with the CTD (i.e., sending CTD setup commands)**.

8. Type @ to exit the setup menu.

9. Click Connect on the Toolbar (or press the Enter key several times) to establish communication with the CTD (through the SBE 36). The system should respond with an S> prompt.

10. Click Status on the Toolbar to send **DS** and display CTD status. If the status displays and is correct, the system is connected properly.

11. If desired, send setup commands to the CTD.

Notes:

- CTD baud rate must be less than or equal to PC baud rate.
- NMEA baud rate is 4800 or 9600.
- Parity selection also affects the communication data bits:
even parity = 7 data bits,
no parity = 8 data bits.
- Changing *PC baud rate* or *parity* disrupts communications, because they must match the settings in Seaterm's Configure menu. See *Changing Communication Settings between SBE 36 and Computer* below for changing settings and reestablishing communications.
- If NMEA depth is enabled (using a NMEA depth device as well as a NMEA position device) and/or Surface PAR is enabled, the query for Start Mode changes to include NMEA Depth and/or PAR, as applicable:
new value = echo or add Lat/Lon/**Depth**/**PAR**

12. Send **QS** to put the CTD in quiescent (sleep) state (not applicable to SBE 49 or 50).
13. **If using the SBE 36 with a NMEA device:** Type @ to return to the setup menu. Type 3 and press the Enter key to switch to mode 3. The display looks like this:

Note:

If NMEA depth is enabled (using a NMEA depth device as well as a NMEA position device) and/or Surface PAR is enabled, the description for mode 2 changes to include NMEA Depth and/or PAR, as applicable:

2. Add Lat/Lon/**Depth**/**PAR** to the real-time HEX data from the instrument

SBE 33/36 Deck Unit set up menu:

Modes:

1. Echo characters to and from the instrument
2. Add Lat/Lon to the real-time HEX data from the instrument
3. Transmit Lat/Lon only

Options:

4. Add NMEA Depth to the real-time HEX/Lat/Lon data
5. Do not add NMEA Depth to the real-time HEX/Lat/Lon data
6. Add PAR to the real-time HEX data
7. Do not add PAR to the real-time HEX data

Communications:

8. Change communication settings and start mode
9. Display communication settings and start mode

Diagnostics:

10. enable diagnostic level 1
11. enable diagnostic level 2

the current mode = 3. Transmit Lat/Lon only

enter 1, 2, 3, 4, 5, 6, 7, 8, 9, 10, or 11 followed by Enter, or press @ to exit the set up menu

selection =

Go to **Step 14** to verify proper operation if the SBE 36 is used with a NMEA navigation (position) device.

Go to **Step 15** to verify proper operation if the SBE 36 is used with **both** a NMEA navigation (position) device **and** a NMEA depth device.

Note:

NMEA depth data will not appear in Mode 3. If using both a NMEA navigation device and a NMEA depth device, go to Step 15.

14. **If using the SBE 36 with a NMEA navigation (position) device:** Type @ to exit the setup menu. You should begin seeing NMEA data display in Seaterm. Each time NMEA data is received, the yellow *NMEA Transmit* LED on the SBE 36 should flash.
 - If NMEA data does not appear, verify that the SBE 36 is connected to the NMEA device and that the proper cable is used.
 - See *Section 7: Troubleshooting* for additional instructions if needed.

15. **If using the SBE 36 with a NMEA navigation (position) device and a NMEA depth device:** While in mode 3, type 10 and press the Enter key to switch to mode 10. Mode 10 is a diagnostic mode that passes all raw NMEA characters received to the screen. The response indicates:

the current mode = 3. Transmit Lat/Lon/Depth only
diagnostic level 1 enabled.

Type @ to exit the menu. You should begin seeing **raw** NMEA messages display in Seaterm. Typical RMC and DPT messages are:

```
$LGRMC,123113.21,A,3625.12,N,12121.34,W,1.2,4.5,231294,1.2,a*45<CR><LF>
$$DDPT,0005.4,0000.0*56<CR><LF>
```

See *Appendix I: NMEA Device Message and Data Formats* for a description of all the NMEA messages the SBE 36 can decode.

- If NMEA data does not appear, verify that the SBE 36 is connected to the NMEA device and that the proper cable is used.
- See *Section 7: Troubleshooting* for additional instructions if needed.

16. Turn off power to the SBE 36.

Changing Communication Settings between SBE 36 and Computer

The SBE 36 factory defaults (9600 PC baud, 4800 CTD baud, 8 data bits, no parity) are compatible with our newer instruments (SBE 19*plus*, 19*plus* V2, 25*plus*, 49, 50). If communication settings in Seaterm's Configure menu do not match the settings in the SBE 36, the display shows *garbage* characters when you power up the SBE 36. This happens most often when using the SBE 36 for the first time with an SBE 19 or 25, which require 7 data bits and even parity.

The procedure below applies to using an SBE 19 or 25 with an SBE 36 set at factory defaults. **Once you change communication settings in the SBE 36, it will retain the new settings, even if you remove power.**

1. In Seaterm's Configure menu, select the **SBE 19*plus***, regardless of which CTD you are using. This allows you to establish communications using the SBE 36 defaults, so that you can then change the communications settings to match your CTD.
2. In the Configuration Options dialog box, click on the COM Settings tab. Set the baud rate to 9600, data bits to 8, and parity to none.
3. In the Communications menu, select *Send 5 second break*.
4. Wait at least 10 seconds. Turn power to the SBE 36 off and then on again. The display in Seaterm should look like this:

```
SBE 33/36 Deck Unit V3.0 setup:
PC baud rate = 9600
CTD baud rate = 4800
8 data bits, no parity
NMEA baud rate = 4800
NMEA messages decoded = GGA, GLL, RMA, RMC, TRF, DBT, DPT
Surface PAR disabled
NMEA depth disabled
start mode = echo characters to and from the instrument
Press @ to change the 33/36 Deck Unit setup
```

5. Type @ to change the SBE 36 setup. Type 8 and press the Enter key to change the communication settings in the SBE 36 to those required for use with your CTD (SBE 19 or 25 – 7 data bits and even parity; SBE 19*plus*, 19*plus* V2, 25*plus*, 49, or 50 - 8 data bits and no parity; see CTD configuration sheet for CTD baud rate). The display looks like this:

```
PC baud rate = X, new value = (type desired value, press Enter)
CTD baud rate = X, new value = (type desired value, press Enter)
parity = X, new value = even parity or no parity [e/n] (type e or n, press Enter)
NMEA baud rate = X, new value = (type desired value, press Enter)
Start mode = X, new value = echo or add Lat/Lon [e/a] (type e or a, press Enter)
```

The display then shows your new selections. Type @ to return to the setup menu.

6. In the Configure menu, select the actual CTD you are using (for 19*plus* V2 or 25*plus*, select SBE 19*plus*). On the COM Settings tab, select settings to match the settings you input to the SBE 36 in Step 5. Click *OK* to save the settings and exit the dialog box.
7. Turn power to the SBE 36 off and then on again. The display in Seaterm should look like this if you set it up for an SBE 19 or 25:

```
SBE 33/36 Deck Unit V3.0 setup:
PC baud rate = 9600
CTD baud rate = 4800
7 data bits, even parity
NMEA baud rate = 4800
NMEA messages decoded = GGA, GLL, RMA, RMC, TRF, DBT, DPT
Surface PAR disabled
NMEA depth disabled
start mode = echo characters to and from the instrument
Press @ to change the 33/36 Deck Unit setup
```

8. Continue testing, starting at Step 8 in *Setting Up and Testing System* above.

Note:

Send 5 second break resets the communication settings in the SBE 36 to factory defaults:

- PC baud rate 9600
- CTD baud rate 4800
- 8 data bits, no parity
- NMEA baud rate 4800

Notes:

- CTD baud rate must be less than or equal to PC baud rate.
- NMEA baud rate is 4800 or 9600.
- Parity selection also affects the communication data bits: even parity = 7 data bits, no parity = 8 data bits.
- If NMEA depth is enabled (using a NMEA depth device as well as a NMEA position device) and/or Surface PAR is enabled, the query for Start Mode changes to include NMEA Depth and/or PAR, as applicable:
new value = echo or add Lat/Lon/**Depth/PAR**

Checking CTD Configuration (.xmlcon or .con) File in Seasave

Notes:

- Seasave and SBE Data Processing versions 7.20 introduced .xmlcon files (in XML format). Versions 7.20 and later allow you to open a .con or .xmlcon file, and to save it to a .con or .xmlcon file. Seasave and SBE Data Processing use the same configuration file.
- A new or recalibrated CTD ships with a configuration file that reflects the current configuration *as we know it*. The file is named with the CTD serial number, followed by a .xmlcon extension. For example, for a CTD with serial number 2375, Sea-Bird names the file *2375.xmlcon*. You may rename the file (but not the extension) if desired; this will not affect the results.
- Seasave and SBE Data Processing are incompatible with an SBE 50 used with the SBE 36/PDIM. You can display data from this system in Seaterm. Surface PAR data (if applicable) is output as raw data.

Seasave, our real-time data acquisition and display program, requires a configuration file, which defines the CTD - auxiliary sensors integrated with the CTD, and channels, serial numbers, calibration dates, and coefficients for all the integrated sensors (conductivity, temperature, and pressure as well as auxiliary sensors). Seasave (and our data processing software) uses the information in the configuration file to interpret and process the raw data. **If the configuration file does not match the actual instrument configuration, the software will not be able to interpret and process the data correctly.**

The configuration file must indicate if NMEA and/or PAR data is being added to the CTD data. The configuration file setup overrides the programmed settings in the SBE 36. In other words, real-time transmission via Seasave of NMEA position data, NMEA depth data, and/or Surface PAR data is dependent on the configuration file settings, not on the SBE 36 settings.

To verify the contents of the .xmlcon or .con configuration file:

1. Double click on Seasave.exe.
2. Click Configure Inputs. On the Instrument Configuration tab, click *Open*. In the dialog box, select the .xmlcon or .con file and click Open.
3. The configuration information appears on the Instrument Configuration tab. Verify that the sensors match those on your instrument, and that auxiliary sensors are assigned to the correct channels. Click *Modify* to bring up a dialog box (example shown below is for SBE 19plus) to change the configuration and/or to view / modify calibration coefficients.

- **NMEA** - Select if NMEA navigation device used, **and** select whether NMEA device is connected directly to Deck Unit **or** to computer. You can also append NMEA depth data (3 bytes) and NMEA time data (4 bytes) after Lat/Lon data. Seasave adds current latitude, longitude, and universal time code to data header; appends NMEA data to every scan; and writes NMEA data to .nav file every time Ctrl F7 is pressed or Add to .nav File is clicked. Note: NMEA time can only be appended if NMEA device connected directly to computer.
- **Surface PAR** - Select if Surface PAR sensor used. Seasave appends Surface PAR data to every scan. Adds 2 channels to Channel/Sensor table. Do not increase *External voltage channels* to reflect this; *External voltage channels* reflects only external voltages going directly to CTD from auxiliary sensor. See Application Note 47.
- **Scan time added** - Select to have Seasave append time (seconds since January 1, 1970 GMT) to each data scan.

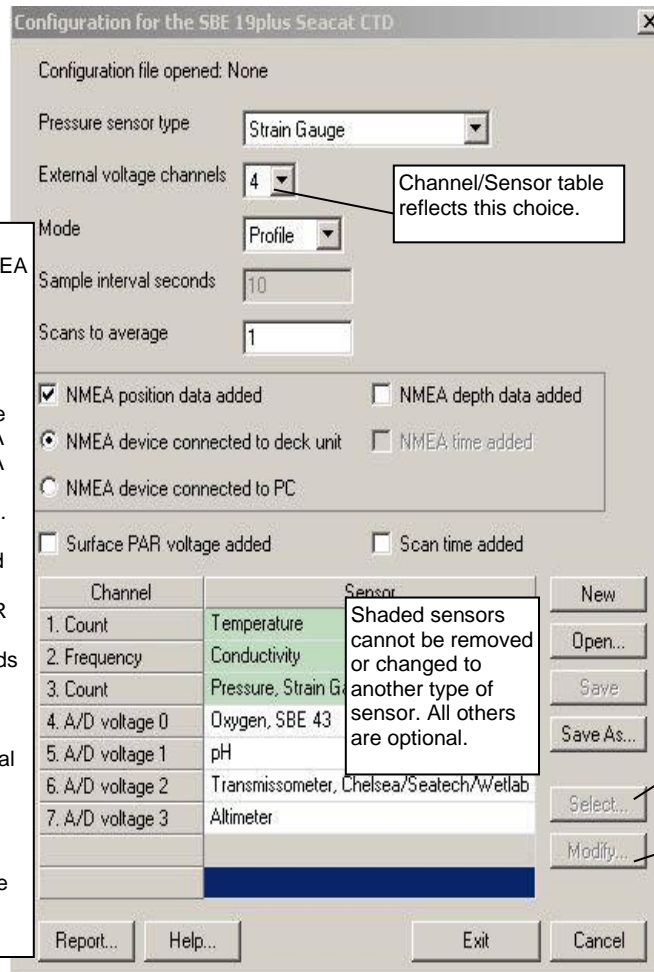

Channel/Sensor table reflects this choice.

Shaded sensors cannot be removed or changed to another type of sensor. All others are optional.

Click a (non-shaded) sensor and click **Select** to pick a different sensor for that channel. A dialog box with a list of sensors appears. Select sensors after number of voltage channels have been specified above.

Click a sensor and click **Modify** to view/change calibration coefficients for that sensor.

4. Click *Save* or *Save As* to save any changes to the .xmlcon or .con file. Click *Exit* when done reviewing / modifying the configuration file.

Section 4: Mounting and Wiring System

This section covers:

- Cable, winch, and deck gear (not supplied by Sea-Bird)
- Mounting the Deck Unit and PDIM
- Wiring the system

Cable, Winch, and Deck Gear (not supplied by Sea-Bird)

The electrical requirements of the armored cable are rather simple. Only one conductor is required (the armor is used as ground), and the total 2-way resistance (conductor plus armor) should be under 350 ohms. The mechanical requirements are most driven by the characteristics of the winch and weight of the payload to be lifted. The winch should have a level wind device that is either adjustable or pre-designed to lay the correct number of wraps across the drum; the cable diameter and drum width determine this. The winch must also be equipped with a slip ring (rotating contact) assembly (at least 2 channels). A cable breaking strength of at least 5 to 7 times the maximum payload weight is recommended for safety and cable longevity. The cable must also be terminated both mechanically and electrically at the underwater (instrument) end. Cable termination (mechanical) at the winch drum is usually addressed by the winch maker. The cable is terminated electrically to the slip ring per the slip ring manufacturer's specification.

Sea-Bird is not expert in winch and deck gear and cannot recommend a block and A-frame. From past experience and with knowledge of what other customers use, we can point out sources for typical cable solutions, and cable terminations suppliers. For links to suppliers of winches, cable, and cable termination hardware, see our website (<http://www.seabird.com/products/third-party-equipment#CableAndWinch>).

Mounting SBE 36 and PDIM

Detachable rack mount *ears* are provided for mounting the SBE 36 Deck Unit to standard 19-inch electronics bays.

Ensure that the back of the SBE 36, specifically the cooling fan and its vent, is not obstructed.

Mount the PDIM to the CTD, using the provided mounting kit.

Wiring System

On the ship, cables longer than 3 meters should be installed inside an earthed metal conduit by a qualified electrician. This minimizes the potential for external signals to disrupt communication and ensures that high voltage lines (such as the sea cable) are sufficiently protected. Cables shorter than 3 meters can be used without shielding when installing or bench testing the instrument.

Note:

The CTD optical isolation feature (SBE 25 - standard; SBE 19 - optional) must be disabled when the CTD is used with the PDIM:

1. Open the CTD main housing.
2. Solder a jumper wire across the neon bulb on the *above board*.

See the CTD manual to access the *above board* and for the board schematic.

This note is not applicable to the SBE 19*plus*, 19*plus* V2, 25*plus*, or 49.

See *Cables and Wiring* in Section 2: *Description of SBE 36 / PDIM* for cable diagrams. See *Connector Mating and Maintenance* in Section 6: *Routine Maintenance* for connector mating details.

PDIM to CTD

Connect the CTD's data I/O connector to the PDIM's 4-pin connector using the cable supplied with the CTD / PDIM.

Sea Cable from SBE 36 to PDIM

Mold the bottom end of the sea cable to the 2-pin pigtail (RMG-2FS or MCIL-2FS) supplied with the PDIM. Connect positive power (+, cable inner conductor) to the small pin (black on the pigtail) and negative power (-, cable armor) to the large pin (white on the pigtail). If you inadvertently connect the power with the wrong polarity, no damage will be done, because there is a protective diode in series with the + power line. However, the system will not work until the condition is corrected. **For safety reasons and for the most reliable performance, Sea-Bird strongly recommends use of the cable armor for the PDIM/CTD data and power return.**

Make a secure mechanical connection between the cable armor and the CTD or cage lifting eye. Connect the sea cable to the PDIM, using care to dress the cable termination so that it will not be pinched by the shackle or clevis. Install a cotter pin or seize the shackle securely.

Terminate the sea cable leads from the winch slip rings with the supplied 2-pin connector (MS3106A12S-3P). Connect positive power (+, cable inner conductor) to pin B and negative power (-, cable armor) to Pin A. Connect to *Sea Cable* on the SBE 36 back panel.

WARNING!

Life threatening voltage (+250 VDC) is present on the sea cable when the SBE 36 is powered. This voltage persists for up to 1 minute after removing power. Verify that the SBE 36 is disconnected from the AC power source before connecting the sea cable to the SBE 36. Unplug the AC power cord and wait 1 minute after power is removed before working on the SBE 36 sea cable connector or sea cable circuits.

SBE 36 to Computer

Connect the computer to *Serial Data* on the SBE 36 back panel using the supplied cable.

WARNING!
Some oceanographic vessels isolate (un-ground) the AC power ground circuit. If the SBE 36 is being installed on a vessel with an isolated AC power ground, a secure separate ground connection must be made between the SBE 36 chassis and the ship's hull for SAFETY REASONS. Attach the hull connection to the protective earthing terminal located on the back panel of the SBE 36 using at least 20 AWG wire and a ring terminal.

CAUTION:
 Connecting an SBE 36 set for 120 volts to a 240 volt power supply will cause severe damage to the SBE 36.

Note:
 NMEA and Surface PAR channels were optional in earlier versions of the SBE 36.

Note:
 SBE 36 can also be used with a Satlantic (Sea-Bird Scientific) Surface PAR sensor. Wiring diagram for that cable is not currently available.

Power to SBE 36

Verify that the SBE 36 back panel power selector switch is in the correct position for your mains power source. Connect power to the *AC Input* connector on the SBE 36 back panel using the supplied cable.

NMEA Navigation Device to SBE 36

Connect the NMEA navigation device to *NMEA Input* on the SBE 36 back panel with the supplied 2-pin MS connector (MS3106A12S-3S). The connector pin designations are:

SBE 36	Function
Pin A	NMEA A (signal)
Pin B	NMEA B (signal return)

Surface PAR Sensor to SBE 36

Connect the Surface PAR sensor to *PAR Input* on the SBE 36 back panel. A 4-pin connector (MS3106A14S-2P) was supplied if a cable was not provided. The connector pin designations are:

SBE 36	Function	Biospherical Surface PAR Sensor with Switchcraft Connector
Pin A	Signal (ground)	Pin 3
Pin B	Power (+12 volts)	Pin 4
Pin C	Power (ground) - SBE 36 with NMEA PCB Assembly 40785b/40786b or greater use pin C. All previous versions do not use pin C.	Pin 1
Pin D	Signal	Pin 2
-	-	Pin 5

Note: Biospherical sold the Surface PAR sensor with other connector types in the past. See the appropriate drawing for pinout details if your sensor does not have a Switchcraft connector.

Section 5: Operating System

This section covers:

- Acquiring real-time data with Seasave
- Recovering the CTD and PDIM
- Uploading CTD data from memory
- Processing data using SBE Data Processing
- Editing raw data file

See *Wiring System* in *Section 4: Mounting and Wiring System* for wiring details.

Acquiring Real-Time Data with Seasave

Note:

When using the **SBE 49 FastCAT** with the SBE 36:

- Seasave 7.23.2 and later supports acquisition of Surface PAR data.
- If the SBE 49 is not set to **AutoRun=Y** (start sampling automatically when power is applied), start sampling by sending the SBE 49 the **Start** command in Seaterm before you run Seasave.

Run Seasave to acquire real-time data (**not applicable to SBE 50**).

Proceed as follows:

1. Double click on Seasave.exe.
2. Click Configure Inputs. The Configure Inputs dialog box appears.
 - A. Click the Serial Ports tab.
 - *CTD Serial Port* - Select the computer port connected to the SBE 36 *Serial Data* connector (which sends commands to and receives replies from the CTD, through the PDIM), and the baud rate, data bits, and parity. The baud rate, data bits, and parity must agree with the SBE 36 setup (see *Setting Up and Testing System* in *Section 3: Setting Up System*).
 - B. Perform any other desired setup in the Configure Inputs dialog box.
 - C. Click OK.
3. Perform any desired setup in the Configure Outputs.
4. Perform any desired setup in the Display menu.

5. In the Real-Time Data menu, select *Start*. The dialog box looks like this:

Data Archiving Options:

- **Begin archiving data immediately** to store raw (frequencies and voltages) real-time data as soon as Start button is clicked and communication is established.
- **Begin archiving data when 'Start Archiving' command is sent** to control when data begins to be written to file. This allows you to eliminate scans associated with deploying CTD from ship deck and soaking instrument near surface (alternatively, remove these scans later in SBE Data Processing). If you make this selection, when you click Start button and communication is established, a dialog box with Start Archiving button appears. Click this button when ready to begin saving scans to file, or select Start Archiving in Real-Time Data menu.
- **Do not archive data for this cast** to not save data to a file. Real-time data will still appear in displays.

Configuration Options: Currently selected instrument configuration (.xmlcon or .con) file is shown, containing information on number and type of sensors interfacing with CTD, calibration coefficients, and inclusion of NMEA and/or Surface PAR data with CTD output. To modify input configuration (.xmlcon or .con file, serial ports, water sampler, TCP/IP ports, and/or miscellaneous), click Configure Inputs. To modify outputs (serial data output, shared file output, mark variables, TCP/IP output, TCP/IP ports, SBE 14 remote display, PC alarms, header form, and/or diagnostics), click Configure Outputs.

- **Timeout in seconds at startup:** Time allowed before first data scan is received from instrument. Seasave will *time out* and stop attempting to acquire data if data is not received from instrument within this time period.
- **Timeout in seconds between scans:** Maximum *gap* allowed between scans *after* first data scan is received from instrument. Seasave will *time out* and stop attempting to acquire data if data is not received from instrument within this time period (for example, if a shark bites cable and interrupts data acquisition, Seasave stops attempting to acquire data after this gap).

Appears in dialog box if .xmlcon or .con file indicates that NMEA data is added through deck unit. If selected, Seasave resets SBE 36 to State 1 when acquisition stops. State 1 is Echo only mode (no NMEA or Surface PAR data is sent), and is useful for setting up CTD.

6. In the Start Real Time Data Acquisition dialog box, click *Start*.
- If you selected *Begin archiving data immediately* or *Begin archiving data when 'Start Archiving' command is sent* above, and selected *Prompt for Header Information* in the Header Form setup (Configure Outputs), the Header Information dialog box appears. Fill in the desired header and click OK.
 - If you selected *NMEA position data added* in the .xmlcon or .con file, Seasave initializes NMEA communications. Seasave automatically sends a command to put the SBE 36 in Mode 1 (do not transmit NMEA data) or Mode 2 (append NMEA and/or Surface PAR data to CTD data), depending on the settings in the configuration file.
 - If you selected *Check Scan Length* in the Options menu, Seasave checks the .xmlcon or .con file to verify that the scan length defined by the configuration file matches the CTD (i.e., number of sensors and inclusion of NMEA and/or Surface PAR is as defined in the file). If a *Scan length error* appears, verify that:
 - You are using the correct .xmlcon or .con configuration file.
 - The configuration file has been updated as necessary if you added or deleted sensors, added or deleted NMEA, etc.

Note:

The SBE 19 (not *19plus* or *19plus V2*) and 25 (not *25plus*) CTD must be in quiescent (sleep) state when the magnetic switch is turned on to start logging. If not, when the switch is turned on the CTD will **not** log data. A common problem is that the user establishes communication *with* the CTD using Seaterm, and then exits Seaterm *without* putting the CTD in quiescent state with the **QS** command. When 2 minutes pass without communication between the computer and CTD, the CTD times out and enters quiescent state automatically. To ensure that Seasave works correctly, verify that the CTD is in quiescent state or is already logging data when Seasave is started.

- D. Seasave sends a message:
 - SBE 19, *19plus*, *19plus V2*, 25, or *25plus*: Seasave message is *Please turn on the . . . using the magnetic switch*. If you have already started logging data, ignore the message; otherwise, move the switch to the On position. For the SBE 19, there may be a wait of up to 1 minute before data appears; for the other CTDs, data starts appearing in a few seconds;
 - SBE 49: Seasave message is *Waiting for data . . .*. Data starts appearing in a few seconds.

Seasave *times out* if data is not received within *Timeout in seconds at startup*.
 - E. Real-time data then starts appearing in the screen displays.
7. To stop logging and real-time data acquisition:
 - A. For an instrument that was started by movement of a switch (such as SBE 19, *19plus*, *19plus V2*, 25, or *25plus*), move the switch to the off position.
 - B. In the Real-Time Data menu, select *Stop*.
 - C. For an instrument that was started by command, close Seasave. Open Seaterm, establish communications with the CTD, and send the appropriate command to stop sampling. Then send the command to put the CTD in quiescent (sleep) state (sleep state not applicable to the SBE 49).

Recovering CTD and PDIM

WARNING!

If the CTD or PDIM stop working while underwater, are unresponsive to commands, or show other signs of flooding or damage, carefully secure the instruments away from people until you have determined that abnormal internal pressure does not exist or has been relieved.

Pressure housings may flood under pressure due to dirty or damaged o-rings, or other failed seals. When a sealed pressure housing floods at great depths and is subsequently raised to the surface, water may be trapped at the pressure at which it entered the housing, presenting a danger if the housing is opened before relieving the internal pressure.

Instances of such flooding are rare. However, a housing that floods at 5000 meters depth holds an internal pressure of more than 7000 psia, and has the potential to eject the end cap with lethal force. A housing that floods at 50 meters holds an internal pressure of more than 85 psia; this force could still cause injury.

If you suspect the PDIM is flooded, point the PDIM in a safe direction away from people, and loosen the 4 screws on the connector end cap about $\frac{1}{2}$ turn. If there is internal pressure, the end cap will *follow* the screws out, and the screws will not become easier to turn. In this event, loosen 1 bulkhead connector very slowly, at least 1 turn. This opens an o-ring seal under the connector. Look for signs of internal pressure (hissing or water leak). If internal pressure is detected, let it bleed off slowly past the connector o-ring. Then, you can safely remove the end cap.

See the CTD manual for instructions on relieving pressure inside the CTD housing.

Rinse the CTD, auxiliary sensors, and PDIM with fresh water.

Uploading CTD Data from Memory

Notes:

- The SBE 49 and SBE 50 do not have a memory for storing data.
- The SBE *25plus* does not transmit real-time data from any auxiliary serial sensors integrated with the CTD; you must upload the data from memory to access the serial sensor data.

Typically, data processing is performed on the real-time data acquired in Seasave. However, some users choose to upload the data in the CTD memory as a back-up to the real-time data. This allows for comparison of the data in memory to the real-time data, to ensure that cable problems, noise, etc. did not corrupt the real-time data.

Upload data from the CTD memory as follows:

1. When the cast is complete, turn the CTD switch off.
2. Turn power to the SBE 36 off.
3. Disconnect the CTD from the PDIM.
4. **Connect the CTD directly to the computer**, using the data I/O cable provided with the CTD. Follow directions in the CTD manual for uploading data.

Processing Data Using SBE Data Processing

Notes:

- See the SBE Data Processing manual and/or Help files.
- SBE Data Processing is incompatible with data from the SBE 50.

1. Use SBE Data Processing's Data Conversion module to convert the **real-time** .hex (raw data) file created by Seasave to a .cnv file, with all data in engineering units.
2. If desired, convert the raw data file (.xml for SBE *25plus*; .hex for all other CTDs) **uploaded** from the CTD memory to a .cnv file in SBE Data Processing's Data Conversion module, for comparison to the real-time data.
3. Once the data is converted: perform further processing (align, filter, remove bad data, etc.), calculate derived variables, and plot data using SBE Data Processing's other modules.

Editing Raw Data File

Sometimes users want to edit the raw data file before beginning processing, to remove data at the beginning of the file corresponding to instrument *soak* time, to remove blocks of bad data, to edit the header, or to add explanatory notes about the cast. **Editing the raw file can corrupt the data, making it impossible to perform further processing using Sea-Bird software.** Sea-Bird strongly recommends that you first convert the data to a .cnv file (using SBE Data Processing's Data Conversion module), and then use other SBE Data Processing modules to edit the .cnv file as desired.

Note:

Although we provide this technique for editing a raw .hex file, **Sea-Bird's strong recommendation, as described above, is to always convert the raw data file and then edit the converted file.**

The procedure for editing a .hex data file described below has been found to work correctly on computers running Windows 98, 2000, and NT. **If the editing is not performed using this technique, SBE Data Processing may reject the edited data file and give you an error message.**

1. **Make a back-up copy of your .hex data file before you begin.**
2. Run **WordPad**.
3. In the File menu, select Open. The Open dialog box appears. For *Files of type*, select *All Documents (*.*)*. Browse to the desired .hex data file and click Open.
4. Edit the file as desired, **inserting any new header lines after the System Upload Time line**. Note that all header lines must begin with an asterisk (*), and *END* indicates the end of the header. An example is shown below (for an SBE 21), with the added lines in bold:

```
* Sea-Bird SBE 21 Data File:
* FileName = C:\Odis\SAT2-ODIS\oct14-19\oc15_99.hex
* Software Version Seasave Win32 v1.10
* Temperature SN = 2366
* Conductivity SN = 2366
* System UpLoad Time = Oct 15 1999 10:57:19
* Testing adding header lines
* Must start with an asterisk
* Place anywhere between System Upload Time & END of header
* NMEA Latitude = 30 59.70 N
* NMEA Longitude = 081 37.93 W
* NMEA UTC (Time) = Oct 15 1999 10:57:19
* Store Lat/Lon Data = Append to Every Scan and Append to .NAV
File When <Ctrl F7> is Pressed
** Ship:          Sea-Bird
** Cruise:       Sea-Bird Header Test
** Station:
** Latitude:
** Longitude:
*END*
```

5. In the File menu, select Save (**not Save As**). If you are running Windows 2000, the following message displays:
You are about to save the document in a Text-Only format, which will remove all formatting. Are you sure you want to do this?
Ignore the message and click *Yes*.
6. In the File menu, select Exit.

Section 6: Routine Maintenance

This section reviews PDIM corrosion precautions, underwater connector mating and maintenance, and cleaning the SBE 36 Deck Unit.

Corrosion Precautions

Rinse the PDIM with fresh water after use and prior to storage. Periodically (yearly), remove the PDIM from the mounting clamps to rinse the entire housing surface with fresh water.

Avoid direct attachment of metal objects to the PDIM housing to prevent corrosion. **Insulate the stainless steel clamps used with the PDIM's mounting bracket with Teflon tape.**

All stainless steel screws that are exposed to salt water have been generously lubricated at the factory with Blue Moly™. After each cruise, remove these screws and re-lubricate them. **This compound is electrically conductive, so use care to ensure it does not get on circuit boards.**

A large zinc anode is screwed in each end cap. Check the anodes periodically to verify that they are securely fastened and have not been eaten away.

Connector Mating and Maintenance

Note:

See *Application Note 57: Connector Care and Cable Installation*.

Clean and inspect connectors, cables, and dummy plugs before every cruise, during a cruise (good practice if you have a few days of down time between casts), after every cruise, and as part of your yearly equipment maintenance. Inspect connectors that are unmated for signs of corrosion product around the pins, and for cuts, nicks or other flaws that may compromise the seal.

When remating connectors for underwater portions of the system:

1. Lightly lubricate the inside of the dummy plug / cable connector with silicone grease (DC-4 or equivalent).
2. **XSG / AG Connector** - Install the cable connector, aligning the raised bump on the side of the cable connector with the large pin (pin 1 - ground) on the end cap. Remove any trapped air by *burping* or gently squeezing the connector near the top and moving your fingers toward the end cap.
OR
MCBH Connector – Install the cable connector, aligning the pins.
3. Place the locking sleeve over the dummy plug / cable connector. Tighten the locking sleeve finger tight only. **Do not overtighten the locking sleeve and do not use a wrench or pliers.**

Verify that a cable or dummy plug is installed for each connector on the system before deployment.

CAUTIONS:

- **Do not use WD-40** or other petroleum-based lubricants, as they will damage the connectors.
- For wet-pluggable MCBH connectors: **Silicone lubricants in a spray can** may contain ketones, esters, ethers, alcohols, or glycols in their propellant. **Do not use these sprays, as they will damage the connector.**

Cleaning SBE 36 Deck Unit

To clean the SBE 36:

1. Disconnect the power and any other cables from the back of the SBE 36.
2. Using a soft cotton cloth dampened with warm water, clean the exterior of the SBE 36 with gentle pressure. Use special care cleaning around any connectors, to avoid getting water into them.
3. Wait until the SBE 36 is completely dry before reconnecting power cables and other electrical connections.

Section 7: Troubleshooting

WARNING!

Life-threatening high voltages are present in the SBE 36 and the underwater units when power is on. These hazardous voltages persist for up to 1 minute after removal of power. To protect against electrical shock, disconnect the AC power cord from the SBE 36 and then wait a full minute before attempting service. Always disconnect the AC power cord before checking fuses.

This section reviews common problems in operating the SBE 36/PDIM, and provides the most likely causes and solutions.

Servicing should be performed by experienced technicians who have been trained to work with complex mechanical/electrical equipment.

For protection of the circuitry, we also recommend removing AC power and then waiting for 1 minute for supply capacitor discharge before opening housings, changing connections, removing or inserting circuit cards, or otherwise working on the equipment.

Problem 1: Unable to View Data in Seasave (Real-Time Data Acquisition program)

Notes:

- If *Check scan length* is enabled in Seasave's Options menu, Seasave checks the data scan length against the expected length (based on the configuration file setup), and provides a warning that there is an error. Sea-Bird recommends using this setting.
- Seasave is incompatible with an SBE 50 used with the SBE 36/PDIM.

Cause/Solution 1: If the scan length does not match the selected .xmlcon or .con configuration file (for example, the configuration file indicates that NMEA position data is added through a NMEA device connected to the computer, but you did not connect the NMEA device to the computer), **Seasave continues with real-time data acquisition (saving the raw data to a file for later processing), but does not show or plot data in the Seasave displays.** The data quality is not affected; you can correct the configuration file error in SBE Data Processing (post-processing), and process the data as required. Verify that the settings in the configuration file match the current CTD configuration - number and type of auxiliary sensors, sensors assigned to correct channels, NMEA and Surface PAR selected if applicable.

Problem 2: SBE 36 Completely Inoperable

WARNING!

Use extreme caution when making these tests.

Cause/Solution 1:

If the power switch is on but the power switch light is out, no other panel lights are on, and the fan is not running, either AC power has been disconnected or the main fuse has blown. Check the AC power source. Turn off the SBE 36, remove the power cable, wait 1 minute, and check the main fuse. Replace if necessary.

If the main fuse blows again, there is probably a short in the main chassis AC wiring. See the chassis wiring diagram - it may be necessary to disconnect one section after another to locate the problem.

Problem 3: CTD Does Not Respond

WARNING!
Use extreme caution when making these tests.

Cause/Solution 1:

There may be no voltage on the sea cable. Turn off the SBE 36, remove the power cable, and wait 1 minute. Connect a voltmeter (range set to at least 300 volts DC) to the back-panel *Sea Cable* connector. Turn on the SBE 36. The voltmeter should read 250V.

If no sea cable voltage is observed, the sea cable supply is inoperative. Turn off the SBE 36, remove the power cable, and wait 1 minute. Check the back-panel *Sea Cable Fuse*. If this fuse is blown, the sea cable may have been inadvertently shorted, or the CTD or PDIM may be malfunctioning. Check the resistance across the sea cable and correct if shorted.

Problem 4: Yellow NMEA Transmit LED Not Flashing

Cause/Solution 1:

Wiring may be incorrect. Check cables and connections between the SBE 36, NMEA navigation device, and computer.

Cause/Solution 2:

NMEA navigation device may be set to the wrong baud rate (SBE 36 requires 4800 or 9600 baud). Reset device's baud rate.

Cause/Solution 3:

NMEA navigation device may not be transmitting data. See the device manual for setup details. To verify that it is sending data, connect an oscilloscope with ground on NMEA B (T17) and the probe on NMEA A (T16). The signal should be less than 0.5 volts between messages and have pulses greater than 4 volts for at least 0.2 milliseconds during the message.

Cause/Solution 4:

SBE 36 may not be operating properly. To verify, use the NMEA simulation program supplied with Seasoft. This program simulates a NMEA navigation device transmitting a NMEA message (see *Appendix II: NMEA Message Simulation Program*).

Problem 5: Yellow NMEA Transmit LED Flashing, but Lat/Lon Data Not Displaying

Cause/Solution 1:

NMEA device may be transmitting a NMEA message that has an unexpected format. See *Appendix I: NMEA Navigation Device Message and Data Formats* for a description of all the NMEA messages the SBE 36 can decode.

Glossary

Note:

All Sea-Bird software listed was designed to work with a computer running Windows XP service pack 2 or later, Windows Vista, or Windows 7 (32-bit or 64-bit).

NMEA Test – Sea-Bird’s Windows NMEA message simulation program, which simulates NMEA messages for testing purposes (installed with SBE Data Processing).

PCB – Printed Circuit Board.

SBE Data Processing – Sea-Bird’s Windows data processing software, which calculates and plots temperature, conductivity, pressure, data from auxiliary sensors, and derived variables such as salinity and sound velocity.

Scan – One data sample containing temperature, conductivity, pressure, and optional auxiliary inputs.

Seasave V7 – Sea-Bird’s Windows software used to acquire, convert, and display real-time or archived raw data.

Seasoft V2 – Sea-Bird’s complete Windows software package, which includes software for communication, real-time data acquisition, and data analysis and display. Seasoft V2 includes **Seaterm**, **SeatermV2**, **Seasave V7**, **SBE Data Processing**.







Seaterm – Sea-Bird’s Windows terminal program used to communicate with the SBE 36 and/or the CTD.

SeatermV2 – Windows terminal program *launcher*. Depending on the instrument selected, it launches Seaterm232 (RS-232 instruments), Seaterm485 (RS-485 instruments), or SeatermIM (inductive modem instruments).

Seaterm232 – Windows terminal program used with Sea-Bird instruments that communicate via an RS-232 interface, and that were developed or redesigned in 2006 and later. The common feature of these instruments is the ability to output status information in XML.

Safety and Electrical Symbols

Some or all of the following symbols may be used on the SBE 36:

Symbol	Description
	Potentially hazardous voltage.
	Hazardous! Voltage > 30 VDC may be present.
	Attention! There is a potential hazard; consult the manual before continuing.
	DC (Direct Current).
	Double insulated. The metal enclosure of the SBE 32 is isolated such that protection from electrical shock is provided through reinforced electrical insulation.
	Static awareness. Static discharge can damage part(s).
	Protective earthing terminal.

Appendix I: NMEA Navigation Device Message and Data Formats

Message Formats

- Notes:**
- represents two device-specific characters.
 - x represents miscellaneous parameters that are ignored by the SBE 36.
 - <CR> is carriage return.
 - <LF> is line feed.
 - See the table below for definitions of message parameters.
 - Seasave and SBE Data Processing are compatible with NMEA depth data in the data stream. NMEA depth data can be decoded and merged with CTD data only if NMEA position data is also available.
 - Seasave supports acquisition of data from a NMEA device connected to the deck unit or connected directly to the computer.

GGA - Global Positioning System Fix Data
 Time, position, and fix related data for a GPS receiver.
 \$--GGA,hhmmss.ss,llll.ll,a,yyyy.yy,b,x,xx,x.x,x.x,M,x.x,M,x.x,xxxx*hh<CR><LF>

GLL - Geographic Position - Latitude/Longitude
 Latitude and Longitude of present position, time of position fix, and status.
 \$-GLL,llll.ll,a,yyyy.yy,b,hhmmss.ss,A*hh<CR><LF>

RMA - Recommended Minimum Specific Loran-C Data
 Position, course, and speed data provided by a LORAN-C receiver.
 \$-RMA,A,llll.ll,a,yyyy.yy,b,x,x,x.x,x.x,x.x,x.x,a*hh<CR><LF>

RMC - Recommended Minimum Specific GPS/TRANSIT Data
 Time, date, position, course, and speed data provided by a GPS or TRANSIT navigation receiver.
 \$-RMC,hhmmss.ss,A,llll.ll,a,yyyy.yy,b,x,x,x.x,ddmmyy,x.x,a*hh<CR><LF>

TRF - TRANSIT Fix Data
 Time, date, position, and information related to a TRANSIT fix.
 \$-TRF,hhmmss.ss,ddmmyy,llll.ll,a,yyyy.yy,b,x,x,x.x,x.x,x.x,xxx,A*hh<CR><LF>

DBT - Depth Below Transducer
 Depth in fathoms, meters, and feet
 \$-DBT,xxxx.x,f,ddd.d,M,xxxx.x,F*hh<CR><LF>

DPT - Depth
 Depth
 \$-DPT,ddd.d,xxxx.x,xxxx.x*hh<CR><LF>

Field Type	Symbol	Definition
Status	A	Single character field: A = Yes, data valid, warning flag clear V = No, data invalid, warning flag set
Latitude	llll.ll	Fixed/Variable length field: degrees minutes.decimal - 2 fixed digits of degrees, 2 fixed digits of minutes, variable number of digits for decimal-fraction of minutes. Leading zeros always included for degrees and minutes to maintain fixed length. Decimal point and associated decimal-fraction optional if full resolution not required.
	a	N or S
Longitude	yyyy.yy	Fixed/Variable length field: degrees minutes.decimal - 3 fixed digits of degrees, 2 fixed digits of minutes, variable number of digits for decimal-fraction of minutes. Leading zeros always included for degrees and minutes to maintain fixed length. Decimal point and associated decimal-fraction optional if full resolution not required.
	b	E or W
Time	hhmmss.ss	Fixed/variable length field: hours minutes seconds.decimal - 2 fixed digits each of hours, minutes, and seconds; variable number of digits for decimal-fraction of seconds. Leading zeros always included for hours, minutes, and seconds to maintain fixed length. Decimal point and associated decimal-fraction optional if full resolution not required.
Depth	ddd.d (see note at right)	Depth below transducer in meters. Note: Format can be dddd.d or ddd.d
Checksum	*	Optional Checksum Delimiter.
	hh	Optional Checksum Field: Absolute value calculated by exclusive OR'ing 8 data bits (no start or stop bits) of each character in message, between, but excluding \$ and *.

Data Formats

Note:

If a Surface PAR sensor is also connected to the SBE 36, the Surface PAR data (three bytes) is appended *before* the position data.

Position Data

Seven bytes of NMEA position data are appended to each scan of hex data from the instrument.

Our software calculates latitude and longitude as follows:

$$\text{Latitude (deg)} = (\text{byte 1} * 65536 + \text{byte 2} * 256 + \text{byte 3}) / 50000$$

$$\text{Longitude (deg)} = (\text{byte 4} * 65536 + \text{byte 5} * 256 + \text{byte 6}) / 50000$$

Notes:

1. If bit 1 in byte 7 is 1, this is a new position.
2. If bit 8 in byte 7 is 1, Latitude is negative.
3. If bit 7 in byte 7 is 1, Longitude is negative.
4. North latitudes are positive, south latitudes are negative.
5. East longitudes are positive, west longitudes are negative.

Example:

Appended position data = 2455FC5D32B141

byte 1 = 24 hex = 36 decimal

byte 2 = 55 hex = 85 decimal

byte 3 = FC hex = 252 decimal

byte 4 = 5D hex = 93 decimal

byte 5 = 32 hex = 50 decimal

byte 6 = B1 hex = 177 decimal

byte 7 = 41 hex = 01000001 binary

This is a new position (bit 1 in byte 7 is 1).

Latitude is positive (bit 8 in byte 7 is 0).

Longitude is negative (bit 7 in byte 7 is 1).

Latitude = $(36 * 65536 + 85 * 256 + 252) / 50000 = 47.62616$ degrees

Longitude = $(93 * 65536 + 50 * 256 + 177) / 50000 = -122.1565$ degrees

Depth Data (if applicable)

Three bytes of depth data are appended to each scan of data, after the position data.

Our software calculates depth as follows:

$$\text{Depth (meters)} = (\text{byte 1} * 65536 + \text{byte 2} * 256 + \text{byte 3}) / 10$$

Example:

Appended depth data = 0032FC

byte 1 = 00 hex = 0 decimal

byte 2 = 32 hex = 50 decimal

byte 3 = FC hex = 252 decimal

Depth = $(0 * 65536 + 50 * 256 + 252) / 10 = 1305.2$ meters

Appendix II: NMEA Message Simulation Program

Sea-Bird provides a NMEA message simulation program, NMEATest, as a troubleshooting aid. NMEATest, part of the Seasoft V2 package, simulates a NMEA navigation device transmitting NMEA messages. If the system does not work with the actual NMEA navigation device, but works with NMEATest, the problem is with the interface cable from the NMEA navigation device to the SBE 36 or in the NMEA navigation device itself.

Note:

While NMEATest can *generate* messages in only the four formats shown, it can *run* using an existing raw NMEA data file in these formats as well as TRF, DBT, and DPT.

NMEATest is just a simulation, and does not provide an actual data stream from an actual NMEA navigation device. The data transmission baud rate (4800 or 9600) and time between messages are user-programmable. The NMEA message format (RMA, RMC, GLL, or GGA) generated by the program is also user-programmable. Alternatively, the user can specify an existing raw NMEA data file to use for the simulation; see *Appendix I: NMEA Navigation Device Message and Data Formats* for the required raw data format.

Note:

You can also run the simulation using only one computer, if the computer has a spare COM port.

To execute the simulation program, a **second computer** (computer 2) is needed to emulate the NMEA navigation device. A laptop computer is adequate for this purpose. Install NMEATest on computer 2 (NMEATest is part of the SBE Data Processing installation).

Note:

The SBE 36 must be connected to the PDIM to test the NMEA interface. If it is not connected, noise on the open *Sea Cable* connector will interfere with communication with the SBE 36.

Use the NMEA Interface test cable (PN 801422 – supplied with the SBE 36) to connect *NMEA Input* on the SBE 36 to the simulation computer. The simulation test cable connections are:

MS3102A12S-3P	DB-9S	Function
Pin A	Pin 3	NMEA A (signal)
Pin B	Pin 5	NMEA B (signal return)

Proceed as follows (instructions are written assuming you are using a second computer to emulate the NMEA navigation device):

1. On computer 1, set up Seaterm to communicate with the SBE 36 at 9600 or 19200 baud, 7 or 8 data bits, no or even parity (Steps 1 and 2 in *Setting Up and Testing System* in *Section 3: Setting Up System*).
2. Turn on power to the SBE 36. The SBE 36 status message displays in Seaterm:

```
SBE 33/36 Deck Unit V3.0 setup:
PC baud rate = 9600
CTD baud rate = 4800
8 data bits, no parity
NMEA baud rate = 4800
NMEA messages decoded = GGA, GLL, RMA, RMC, TRF, DBT, DPT
Surface PAR disabled
NMEA depth disabled
start mode = echo characters to and from the instrument
Press @ to change the 33/36 Deck Unit setup
```

3. Type @ to access the setup menu.
4. Type 3 and press the Enter key to switch to mode 3.

5. When in mode 3:
 - A. Type *10* and press the Enter key to switch to mode 10. Mode 10 transmits all NMEA messages in raw form. The menu response indicates that the SBE 36 has *diagnostic level 1 enabled*.
 - B. Type *11* and press the Enter key to switch to mode 11. Mode 11 transmits NMEA messages in decoded form. The menu response indicates that the SBE 36 has *diagnostic level 1 enabled* and *diagnostic level 2 enabled*, so NMEA messages will be transmitted in raw form followed by decoded form.
6. On computer 2, double click on **nmeatest.exe** (in same directory as SBE Data Processing). The NMEATest screen appears.
7. On the NMEATest screen, click on the Configure menu. The Configure dialog box appears. Select:
 - NMEA message to be simulated (RMA, RMC, GLL, or GGA) **or** select an existing NMEA data file on your computer by clicking *Send File* and browsing to the desired file. If selecting a NMEA data file, the NMEA message must be compatible with the SBE 36 (GGA, GLL, RMA, RMC, TRF, DBT, or DPT).
 - Baud rate for transmission of simulated NMEA data to SBE 36 (4800 or 9600) – **must match SBE 36 setup**
 - COMM port on computer 2 for transmission of NMEA data to SBE 36.
 - Message interval (time between simulated messages to be transmitted to SBE 36).Click OK.
8. On the NMEATest screen, click Start. NMEA data should begin to display on the NMEATest screen on computer 2 and in Seaterm on computer 1. The yellow *NMEA transmit* light should flash each time the simulation program transmits a new position.

The data displayed by Seaterm should correspond to that of the simulation program (see *Appendix I: NMEA Navigation Device Message and Data Formats* for the raw and decoded NMEA message formats). If properly decoded data appears on the screen, the SBE 36 is working properly. If the system works with the simulation program but does not work when connected to the actual NMEA navigation device, the problem is with the cable from the NMEA navigation device to the SBE 36, or in the NMEA navigation device itself.

- Verify that the cable pinouts are correct, especially at the NMEA navigation device. See *Wiring System* in *Section 4: Mounting and Wiring System* and also refer to the NMEA navigation device documentation.
- If the cable is correct, verify that the NMEA navigation device is on and is configured to send data. Many NMEA navigation devices have programmable NMEA outputs and may need to be configured before they will transmit NMEA messages. Again, refer to the NMEA navigation device documentation, or contact the device's manufacturer for customer support.

Appendix III: PDIM Electronics Disassembly/Reassembly



Jackscrew kit

Sea-Bird provides a jackscrew kit with the PDIM, to assist in removal of the connector end cap. The kit contains:

- 2 Allen wrenches
- 3 jackscrews
- 2 spare plastic socket hex-head screws

Disassembly

Remove the connector end cap and attached electronics PCB assembly as follows:

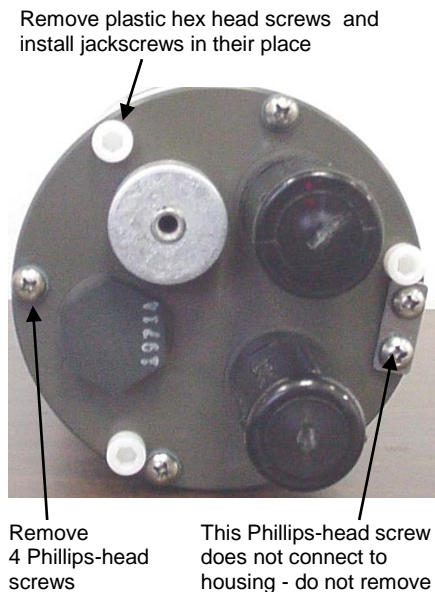

Remove 4 Phillips-head screws

This Phillips-head screw does not connect to housing - do not remove

1. Wipe the outside of the end cap and housing dry, being careful to remove any water at the seam between them.
2. Remove the four Phillips-head screws securing the end cap to the housing.
3. Remove the three plastic hex head screws from the end cap using the larger Allen wrench. Insert the three jackscrews in these three holes in the end cap. When you begin to feel resistance, use the smaller Allen wrench to continue turning the screws. Turn each screw 1/2 turn at a time. As you turn the jackscrews, the end cap will push away from the housing. When the end cap is loosened, pull it and the PCB assembly out of the housing.
4. Remove any water from the O-ring mating surfaces inside the housing with a lint-free cloth or tissue.
5. Disconnect the Molex connector connecting the PCB assembly to the PDIM.
6. Remove the jackscrews from the end cap.

Reassembly

1. Remove any water from the O-ring and mating surfaces with a lint-free cloth or tissue. Inspect the O-ring and mating surfaces for dirt, nicks, and cuts. Clean or replace as necessary. Apply a light coat of O-ring lubricant (Parker Super O Lube) to O-ring and mating surfaces.
2. Reconnect the Molex connector to the PCB assembly.
3. Carefully fit the PCB assembly into the housing, aligning the holes in the end cap and housing.
4. Reinstall the 4 Phillips-head screws to secure the end cap to the housing.
5. Reinstall the 3 plastic hex head screws in the end cap.

Note:

Before delivery, a desiccant package is inserted in the housing and the electronics chamber is filled with dry Argon gas. These measures help prevent condensation. To ensure proper functioning:

1. Install a new desiccant bag each time you open the electronics chamber. If a new bag is not available, see *Application Note 71: Desiccant Use and Regeneration (drying)*.
2. If possible, dry gas backfill each time you open the housing. If you cannot, wait at least 24 hours before redeploying, to allow the desiccant to remove any moisture from the housing.

Note that opening the battery compartment does not affect desiccation of the electronics.

Appendix IV: Replacement Parts

Part Number	Part	Application Description	Quantity
171887	9-pin DB-9F to 9-pin DB-9M cable, 3 m (10 ft)	Connects <i>Serial Data</i> on SBE 36 to computer COM port	1
801422	2-pin MS3106A-12S-3S to 9-pin DB-9S NMEA Interface test cable, 1.8 m (6 ft)	Connect <i>NMEA Input</i> on SBE 36 to computer running NMEA simulation program for test purposes	1
171888	25-pin DB-25S to 9-pin DB-9P cable adapter	For use with computer with DB-25 connector	-
17015	SBE 36 power cable	Connect SBE 36 to AC power source	1
80591	2-pin MS3106A-12S-3P to 2-pin RMG-2FS cable, 2.4 m (8 ft)	Connect <i>Sea Cable</i> on SBE 36 to PDIM for testing	1
17088	4-pin RMG-4FS to 4-pin RMG-4FS cable, 1.1 m (3.8 ft)	Connect PDIM to CTD	1
801367	4-pin MS3106A-14S-2P to 5-pin Switchcraft EN3C5F cable, 15 m (50 ft)	Connect <i>PAR Input</i> on SBE 36 to Biospherical Surface PAR sensor with Switchcraft connector	1
50092	SBE 16/19 Jackscrew kit	For removing PDIM connector end cap	1

Appendix V: Manual Revision History

Manual Version	Date	Description
001	01/95	<ul style="list-style-type: none"> Initial release.
002	08/95	<ul style="list-style-type: none"> Add Surface PAR capability.
003	05/00	<ul style="list-style-type: none"> Add note to disable optical isolation feature in SBE 25/19 when using with 36/PDIM. Update to Windows software.
004	02/02	<ul style="list-style-type: none"> Add use with SBE 19<i>plus</i>. Complete rewrite, add illustrations.
005	05/02	<ul style="list-style-type: none"> SBE 36 added to Seaterm's list of instruments; update Seaterm description.
006	11/02	<ul style="list-style-type: none"> Correct power specification from 50/400 to 50/60 Hz. Update use of NMEA simulation software to Windows version (NMEATest).
007	05/03	<ul style="list-style-type: none"> Update to 9 pin computer connectors throughout. Update Surface PAR with new Biospherical product number Add use with SBE 49.
008	01/04	<ul style="list-style-type: none"> Added more information about SBE 49 setup for use with 36/PDIM. Add more information about PDIM: weight, electronics disassembly/reassembly, wet-pluggable connectors, routine maintenance. Update for Seaterm changes
009	03/04	<ul style="list-style-type: none"> Correct SBE 36 dip switch factory setting (CTD to PDIM communications): 4800 baud, not 600.
010	03/05	<ul style="list-style-type: none"> Add more information on accessing and setting dip switches. Update information on jackscrew kit. Correct wet-pluggable connector callout.
011	03/06	<ul style="list-style-type: none"> NMEA firmware 2.3: allows selection of data bits and parity on PCB dip switch. Add detailed dimensional information and weight. Update recovery warning to provide more detail. Update information on testing NMEA and system setup.
012	04/07	<ul style="list-style-type: none"> Incorporate Seasave V7 – update all descriptions of how to set up & use Seasave, update 19plus .con file screen capture to show 'scan time added' field. Update wet-pluggable connector callout.
013	04/08	<ul style="list-style-type: none"> Update for use with 19plus V2. Update .con dialog box for 19plus to show <i>NMEA depth data added</i> selection. Update real-time data acquisition dialog box, showing selection for resetting to state 1 (echo only, no NMEA data) when cast complete.
014	02/09	<ul style="list-style-type: none"> Update .con file screen capture for Seasave/Data Processing 7.18. Add note that NMEA can go directly to computer. Add note to turn off CTD magnetic switch before stopping data acquisition, so putting deck unit back into state 1 is successful. Delete references to SCPlusV2 terminal program, replaced with SeatermV2. Add information about software compatibility with Vista. Add information on 25 with 36/PDIM– if have NMEA + Surface PAR + > 4 voltages, deck unit can not keep up. Set 25 to output real-time at 4 Hz or less (instead of 8 Hz maximum rate). Update information on connector maintenance, consistent with application note 57.

Continued on next page

Continued from previous page

015	03/10	<ul style="list-style-type: none"> • Electronics redesign: 1 PCB, NMEA is standard. Dip switches are gone, replaced by commands. Serial Data and Carousel Data connectors now 9-pin; changed cables that ship with deck unit. • Changes required for CE certification. • New photo and drawing of back panel. • Update software name. • Add information about .xmlcon file. • Seasave 7.19: <ul style="list-style-type: none"> - Allows acquisition of NMEA depth data for all profiling CTDs. - Allows acquisition of NMEA data for SBE 49. • Add information on use of SBE 50 with SBE 36/PDIM. • Add information that must be in Mode 1 (characters to/from CTD pass thru 36) if trying to send command to CTD thru 36. • Update SBE address.
016	04/12	<ul style="list-style-type: none"> • Add information on use with SBE 25<i>plus</i> CTD. • Add information about ordering cable, winch, and deck gear. • Add more troubleshooting information. • Add information about software compatibility with Windows 7. • Add information about launching Seaterm from SeatermV2.
017	04/13	<ul style="list-style-type: none"> • Add Declaration of Conformity. • Show Surface PAR channel as standard (was optional). • Add cable and wiring diagrams. • Update software compatibility information.
018	08/13	<ul style="list-style-type: none"> • Correct descriptions of Yellow CTD Transmit LED and Green CTD Received LED (descriptions were reversed). • Update to include 'PDIM' in file name. • Correct date for manual version 001 in this revision history to 01/95 (was 01/05).
019	03/14	<ul style="list-style-type: none"> • Add information that Seasave 7.23.2 allows Surface PAR acquisition with SBE 49. • Remove references to requiring version 7.19 or later of Seasave (7.19 was released > 4 years ago). • Update Declaration of Conformity. • Add caution on using spray can lubricants on MCBH connectors. • Remove <i>standard</i> and <i>optional</i> language for connectors.
020	05/16	<ul style="list-style-type: none"> • Update photos and dimensions for new deck unit housing. • Update language on where to find updated software on website. • Update link to cable and winch supplier page on website. • Add SeatermV2 screen capture. • Update Declaration of Conformity. • Switch to Sea-Bird Scientific cover.
021	07/17	<ul style="list-style-type: none"> • Add information on compatibility with Satlantic Surface PAR sensor. • Add PDIM depth rating (6800 m) to description and specifications. • Update information on configuration file that ships with instrument (.xmlcon file, not .con file). • Switch to new Sea-Bird Scientific manual cover.

Index

.con file · 27
.xmlcon file · 27

B

Back panel · 11
Baud rate · 16, 20, 31

C

Cables · 12, 28
CE certification · 3
Cleaning · 37
Communications · 16
Configuration file · 27
Connectors · 10, 37
Corrosion precautions · 37
CTD
 configuration file · 27
 setup · 20, 23
 upload · 35

D

Data bits · 16
Data processing · 35
Data upload · 35
Deck gear · 28
Declaration of Conformity · 3
Description · 8
Dimensions · 9, 10

E

Editing data files · 36
Electrical symbols · 42
Electronics disassembly/reassembly · 47
End cap · 37

F

Front panel · 11

G

Glossary · 41

I

Installation · 28, 29

M

Maintenance · 37
Manual revision history · 49
Mounting · 28

N

NMEA · 17, 23, 30
 data formats · 43
 message formats · 43
 simulation program · 45
 troubleshooting · 40
NMEATest · 9, 19, 45

O

Operating modes · 17
Operating system · 31

P

Parity · 16
Parts
 replacement · 48
PDIM
 connectors · 10
 dimensions · 10
Processing data · 35

R

Real-time acquisition · 31
Recovery · 34
Replacement parts · 48
Revision history · 49
Routine maintenance · 37

S

Safety symbols · 42
SBE 36
 back panel · 11
 front panel · 11
SBE Data Processing · 9, 19
Sea cable · 28
Seasave · 9, 19, 27, 31
Seasoft · 9, 19
Seaterm · 9, 19, 20, 45
 main screen · 21
SeatermV2 · 9, 19
Setup · 23
Slip ring · 28
Software · 9, 19
Specifications · 9
Surface PAR · 17, 30
System communications · 16
System description · 8
System operation · 31
System wiring · 29

T

Testing · 23
Troubleshooting · 39

U

Unpacking SBE 36 / PDIM · 7
Uploading data · 35

V

Versions · 49

W

Winch · 28
Wiring · 12, 29